



## Concept

For over 20 years, the mineral material STARON<sup>®</sup> has been used in high-end interior work and furniture design.

In cooperation with architects and designers, as well as with qualified fabricators, new areas of application, experience and knowledge are constantly being opened up worldwide. Our aim is to qualify and pool this experience and knowledge, providing them to our customers, architects and property developers within the scope of an efficient, creative communication network.

With the STARON<sup>®</sup> Planning Manual, we have created a communication tool which assists with these tasks.

The Planning Manual is to be understood as an open documentation which is continuously updated through future projects, new technical knowledge as well as modifications and expansions of the product range.

## Individual & creative

Use the STARON<sup>®</sup> Planning Manual to document your personal STARON<sup>®</sup> projects and technical designs.

Please inform us about your creative projects and experiences.

We continuously integrate your projects and references and inform architects, planners, builders and investors individually and worldwide.

Your STARON<sup>®</sup> team  
Samsung Chemical Europe GmbH

## Contact



### Customer service:

Samsung Chemical Europe GmbH

Phone: +49 6196 66 74 34

E-mail: [architect@samsung.com](mailto:architect@samsung.com)

[www.staron-samsung.com](http://www.staron-samsung.com)



**SAMSUNG SDI**



**SAMSUNG SDI**

<b>1 Overview</b>	Product description Areas of application Fabrication	Product properties About us Warranty and service
<b>2 Furnishings and Design</b>	Introduction Kitchen Bath Public buildings Airport Office and administration Cultural facilities Hotel	Gastronomy Shopfitting Health care Motor home, train and yacht interior finishing Wall designs Facade design Artistic and practical objects
<b>3 Product Overview</b>	STARON <sup>®</sup> sheets STARON <sup>®</sup> moulded parts and service contact STARON <sup>®</sup> product descriptions	STARON <sup>®</sup> sheet colours 2015 STARON <sup>®</sup> adhesive Manufactured by Samsung Manufactured by fabricator
<b>4 Planning and Design</b>	Basics Forming and radii Moulded parts technology	Inlays and backlighting Screw connections and heat protection Sublimation printing and surface finish
<b>5 Product Certifications</b>	Certifications Technological parameters	
<b>6 Care, Warranty and Service</b>	Usage and care Damage prevention Care of moulded parts and damage prevention	Warranty and service Disclaimer
<b>7</b>		
<b>8</b>		
<b>9 Reports</b>		
<b>10 Ideas and Notes</b>		



## 1 Overview

Product description  
Areas of application  
Fabrication

Product properties  
About us  
Warranty and service







## What is STARON<sup>®</sup>?

Manufactured by Samsung SDI STARON<sup>®</sup> is a range of styrene-free, acrylic-based solid sheets and moulded parts with mineral fillers.



The solid, homogeneous, non-porous sheet and molded part material is composed of one-third acrylic resin (PMMA) and two-thirds aluminium hydroxide (ATH), a natural mineral derived from bauxite.



The unique properties of mineral-based STARON<sup>®</sup> convince both planners and builders.

Samsung SDI - the former Samsung Cheil Industries Inc. - has been producing STARON<sup>®</sup> sheets and moulded parts since 1991. Samsung manufactures STARON<sup>®</sup> sheets in over 140 individual colours for international use with a wide variety of regional demands on design, colour harmony and areas of application.

The colour palette presented in the following product overview reflects current European trends and the product range based on them. However, individual colour requests are possible in consultation with customers.

## STARON<sup>®</sup> colour palette



**SAMSUNG SDI**

## **STARON® areas of application**

The diversity and innovation of STARON® installations are the result of high-quality industrial production and creative planning in cooperation with quality craftsmanship. STARON® is used in designing hotels, restaurants, business furnishings and public buildings such as museums, administrative buildings, airports and hospitals, among other

applications. These include laboratory facilities, wellness centres, ship and mobile home interior finishing, as well as in private kitchens and baths. When using STARON® for interior design, furniture construction, and even wall and facade cladding in both inside and outside areas, almost no limits are set to the creativity of architects and planners.

## **Hotels and gastronomy**

In the hotel and gastronomy sector, STARON® offers guests a welcoming

atmosphere and hoteliers and restaurateurs a presentable, durable, low-maintenance interior.



## **Shopfitting**

For shopfitting purposes, STARON® is ideal for an exclusive, neutral presentation of products and goods.



## Public areas

In public areas, STARON<sup>®</sup> endows guests and customers with an impressive reception and operators with a timeless elegance.

The translucence of the material allows for individual light effects and an innovative enhancement of product and company presentations.



The non-porous, homogeneous properties of the material and its resultant moisture resistance are the basis for its diverse application in public and semi-public sanitary areas.

## Health care

In the health care sector as well as in interior laboratory and hospital construction, mould and bacteria have no chance, thanks to the nonporous and hygienic qualities of STARON<sup>®</sup>.



## Kitchen



Brunner Küchen

In the kitchen, STARON<sup>®</sup> can be adapted to the most individual customer ideas and is aesthetic, functional and easy to clean. The programme is topped off by an extensive range of sinks.

## Bath

Thanks to its pleasant tactile properties and the ergonomics made possible by its forming characteristics, STARON<sup>®</sup> makes it highly inviting to stay in the bath a while!



Oesch AG

## STARON® processing

STARON® is machined with carbide-tipped cutting tools in wood processing plants. The essential processing steps are:

- sawing
- milling
- drilling
- bonding
- forming
- sanding

A further area of design which STARON® opens up is sublimation printing. Sublimation technology in combination with translucent STARON® sheets forms the basis for creative illumination projects. In addition, STARON® acts as a robust support and foundation material for innovative images and presentation.

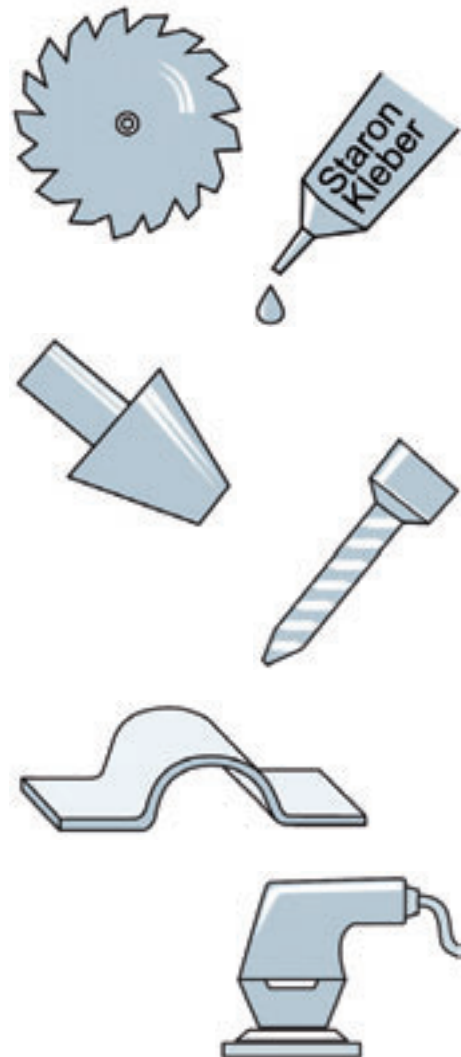

## STARON® product properties

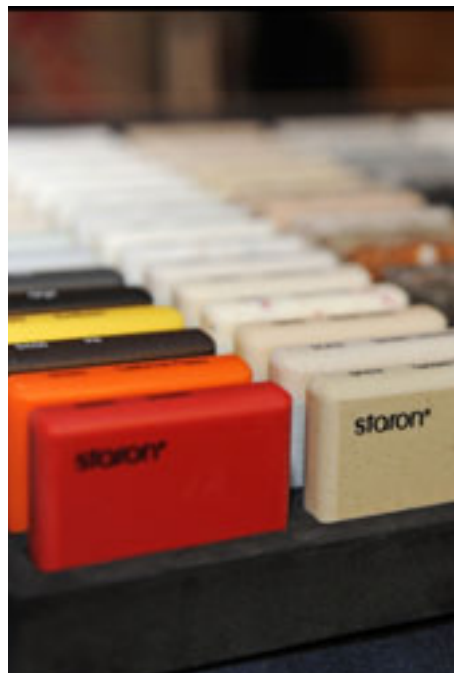

STARON® has outstanding product properties.

STARON® is:

- highly formable
- seamlessly jointed
- repairable
- thermoplastic
- translucent
- durable
- impact-resistant
- stain- and paint-proof
- non-toxic
- robust
- flame resistant
- non-porous
- homogeneous
- hygienic
- low-maintenance
- long-lasting



**SAMSUNG SDI**

## About us

With headquarters in Gyeonggi Do near Seoul, Samsung SDI is an international company and part of the Korean Samsung group, producing high-end screens, batteries and accumulators. The headquarters of its chemical range - former Samsung Cheil Industries Inc. - is based in Gyeonggi Do near Seoul.

The company history of Samsung begins in the year 1938. However, the actual parent company of Samsung was founded with Cheil Industries in 1954. Today a major global company, Samsung SDI has developed into one of the most important manufacturers

in the textile, chemical, electronics, shipbuilding and construction industries. With the STARON® brand, Samsung SDI belongs to the leading global manufacturers of mineral materials. The STARON® manufacturing process is certified according to the Quality Management System ISO-9001. ISO-14001 certification has been awarded for environmental management. Samsung SDI is the parent company of Samsung Chemical Europe GmbH which is based in Schwalbach am Taunus. Samsung Chemical Europe GmbH is responsible for sales and services for STARON® within Europe.

## Warranty

Samsung SDI is convinced of the quality, load capacity and performance of STARON®. This is why Samsung SDI provides owners of STARON® installations for private living areas manufactured in accordance with Samsung processing and application guidelines with a limited 10-year warranty.

Samsung has been cooperating with a global network of STARON® fabricators. The specialisation of these companies for more than 20 years, allows for cost-effective series manufacture, individual single-item manufacture and integrated solutions in the form of furniture and interior work, including turn-key installations – worldwide.

## Service

Our extensive know-how is based on the experience we have gained in manufacturing, planning and processing STARON® over many decades.

Samsung gives customers and planners access to this know-how in the scope of cooperative service programmes for current projects and future product developments.



### Customer service:

Samsung Chemical Europe GmbH

Phone: +49 6196 66 74 34

E-mail: [architect@samsung.com](mailto:architect@samsung.com)

[www.staron-samsung.com](http://www.staron-samsung.com)



**SAMSUNG SDI**



**SAMSUNG SDI**

## **2 Furnishings and Design**

Introduction

Kitchen

Bath

Public buildings

Airport

Office and administration

Cultural facilities

Hotel

Gastronomy

Shopfitting

Health care

Motor home, train and yacht interior finishing

Wall designs

Facade design

Artistic and practical objects







## Introduction

### Aspects

The installations shown in this section will give you a first impression of the versatility in design of STARON<sup>®</sup>. The examples are intended to provide suggestions, not to represent the full product and design potential of STARON<sup>®</sup>. Through their timeless elegance and outstanding material properties, STARON<sup>®</sup> installations remain economical and presentable, even for many years. This documentation is intended as a basis of information for hoteliers, store managers, facility managers, hospital operators and architects, among others, as well as a source of inspiration for future projects. Always open to new developments and designs, we are interested in working together with our customers and for our customers to expand and improve this documentation continuously so that it always remains up to date. For this reason, we are happy to receive any suggestions, contributions and criticism.

STARON<sup>®</sup> furnishings are the result



of high-quality industrial production



and creative planning



in cooperation with quality craftsmanship.



#### Customer service:

Samsung Chemical Europe GmbH

Phone: +49 6196 66 74 34

E-mail: [architect@samsung.com](mailto:architect@samsung.com)

[www.staron-samsung.com](http://www.staron-samsung.com)



**SAMSUNG SDI**

## Kitchen

### Aspects

The practical features encountered in the daily use of STARON® in the kitchen impress the most. Seamless worktop transitions, flush-mounted kitchen sinks and functional elements, as well as a seamless transition to wall cladding with an easy-to-clean inside radius. Form and function can be combined together in designs according to the ideas of planners and users.

### Cubism in the STARON® kitchen

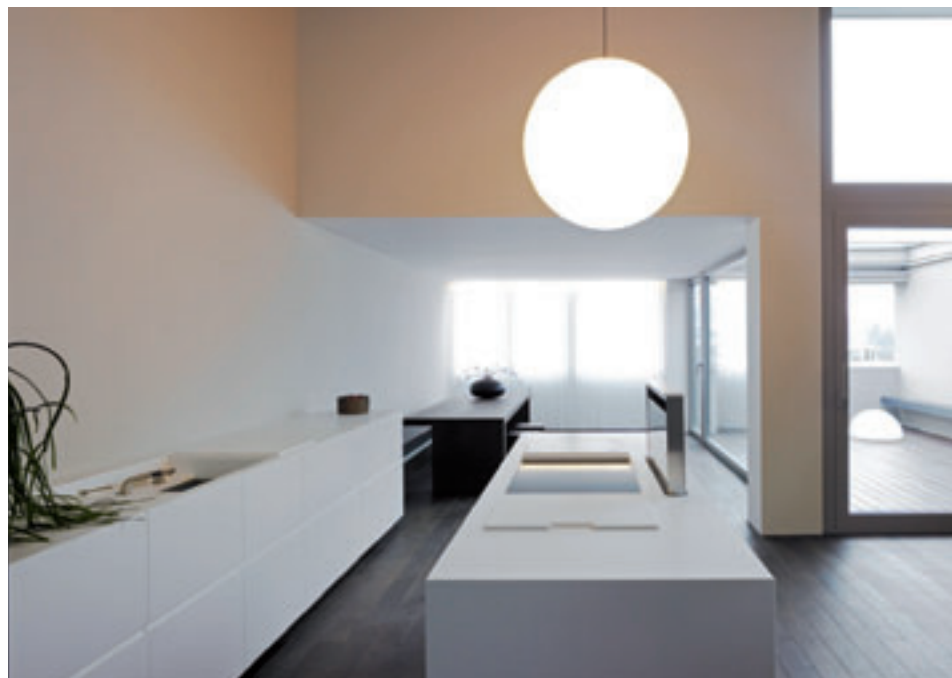

Stuber Team



The cubic kitchen monolith made from STARON® contains all the necessary kitchen elements, from the refrigerator to the oven and the exhaust hood to the sink. However, these elements only become visible when needed. With this monolithic design, this kitchen is integrated completely into the austere geometry of the room.



**SAMSUNG SDI**

Stuber Team

## Kitchen

### Squaring the circle



The circular motif was consistently implemented in this kitchen, both as a whole and in detail.



Trapezoidal geometry is the stylistic highlight of this kitchen.

### **STARON**<sup>®</sup> kitchen sinks

STARON<sup>®</sup> kitchen sinks are functional and design elements are created from finished modules or individually manufactured in accordance with customer specifications.

Possible designs range from strictly cubic forms to circular and semicircular variations.



**SAMSUNG SDI**

## Kitchen

Perfect in form



Brunner Küchen

STARON® corpus elements and fronts and a stainless steel worktop make this kitchen a design highlight. LED lighting and the translucence of STARON® give the kitchen island a floating impression.



Brunner Küchen



Brunner Küchen



The curved STARON® front integrates this drawer in the sink island.

The specific processing potential of STARON® was realised to the full in the table furniture design.

## Kitchen

### Functional elements



These two kitchens impress with their unusual, expressive shapes and integrated functional elements.



### Play of colours

Colours and materials are repeated in the fronts, worktop and recess panel.



## Bath

### Aspects

Planners design adventure and wellness baths with STARON<sup>®</sup> both in detail and in their overall spatial architecture. STARON<sup>®</sup> can be used

as the sole material or in diverse combinations, for example with glass, acrylic, wood, ceramics, stone and stainless steel.

### Washbasins



The double washbasin has the appearance of a stylised fountain. The water taps are discreetly integrated in the mirror.

Even the water drain is harmoniously blended with the overall picture. The base wall of the installation ends as a shower bench.



The material combination of STARON<sup>®</sup> and glass combined with the elegant tap makes this extraordinary design possible.



The double washbasin in the form of a large shell shaped from STARON<sup>®</sup> seems to hover above the strictly geometrical washbasin cabinet.

## Bath

### Bathtubs and showers

The bathtub monoliths are a striking complement to the washbasin models – straight-lined or in elliptical form. Flush shower trays, floor and wall cladding complete the design spectrum.



Stuber Team



## Bath

### Dream baths

STARON® organises and furnishes the bathroom in austere geometrical or flowing forms. Generous surfaces and placement areas are a natural part of all designs. In addition, STARON® adapts itself to room temperature and impresses with its agreeable tactile properties.

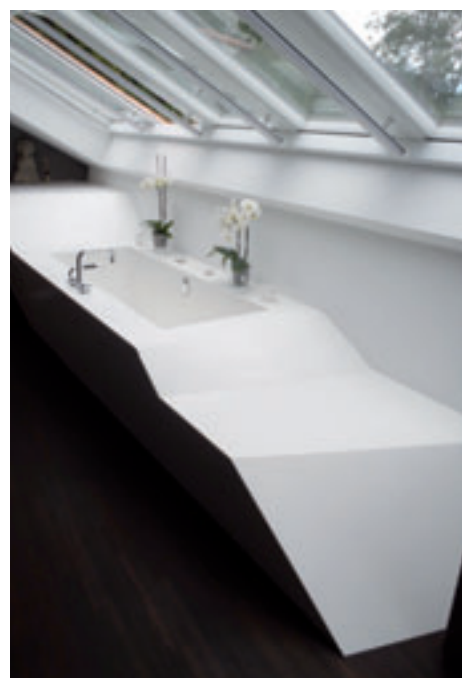



## Bath

### Dream baths



Studer Handels AG



Whether it be a loft design, Japanese stylistic elements, individual inlays in floor and wall designs, washbasin, bathtub or floor-level shower tray – the installation examples showcase the diversity of STARON® "Shades of White".



## Public buildings

### Aspects

Thanks to the many years of use of STARON® worldwide and the creative cooperation with architects and specialist companies, STARON® installations can now be found in such public areas such as:

- Airports
- Railway stations
- Museums
- Libraries
- Banks
- Insurance and administrative buildings
- Care facilities
- Kindergartens
- Schools
- Universities
- Swimming pools and wellness centres

STARON® has an impressive array of positive properties.

STARON® is:

- aesthetically pleasing
- tactile
- functional
- ergonomic
- integrative
- flame resistant
- low-maintenance
- repairable
- robust
- long-lasting



**SAMSUNG SDI**

## Airport

### Check-in terminal



Heathrow, Terminal 5



Airport terminals with STARON® front and corpus elements are ideally designed for the daily rush. All the important functions for personnel and customers are integrated.



## Airport

### Information terminal



This information terminal designed with STARON<sup>®</sup> inlay technology is highly visible to all passengers.



The Internet terminal with the flush-mounted stainless steel keyboard provides further travel information.

### Baggage claim



At baggage facilities, STARON<sup>®</sup> acts as a design, information and functional element.



**SAMSUNG SDI**

## Airport

### Travel agency



STARON® forming technology was used consistently in designing the interior and the furniture of this travel agency.

### Exchange office

The transparent effect of the backlit STARON® front contrasts playfully with the massive STARON® service counter in this exchange office.



### Smoking room



This smoking room was designed entirely with STARON®. Cigarette remains can be removed almost effortlessly from the STARON® surface.



## Office and administration

### Lobby, reception



The reception desk structurally anchors the room. The company logo is incorporated discreetly into the STARON® furniture front as a colour-backlit element.

The reception counter, the work surfaces, the office furniture fronts and the wall elements are manufactured entirely from STARON®.



The CI colours and the company logo are the design elements of this STARON® piece.



SAMSUNG SDI

## Cultural facilities

### Museum display cases

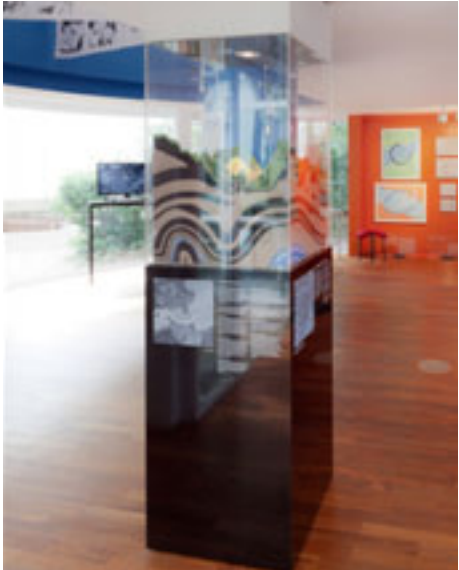

In museums and exhibitions, STARON® furniture showcases exhibits with reserved neutrality, steering the viewer's gaze to the essential.



### Learning and demonstration facilities



Furniture manufactured from STARON® integrates all functions of learning and demonstration facilities, holding up to the heaviest user traffic.



## Cultural facilities

**Dongdaemun  
Design Plaza in  
Seoul, South-Korea**

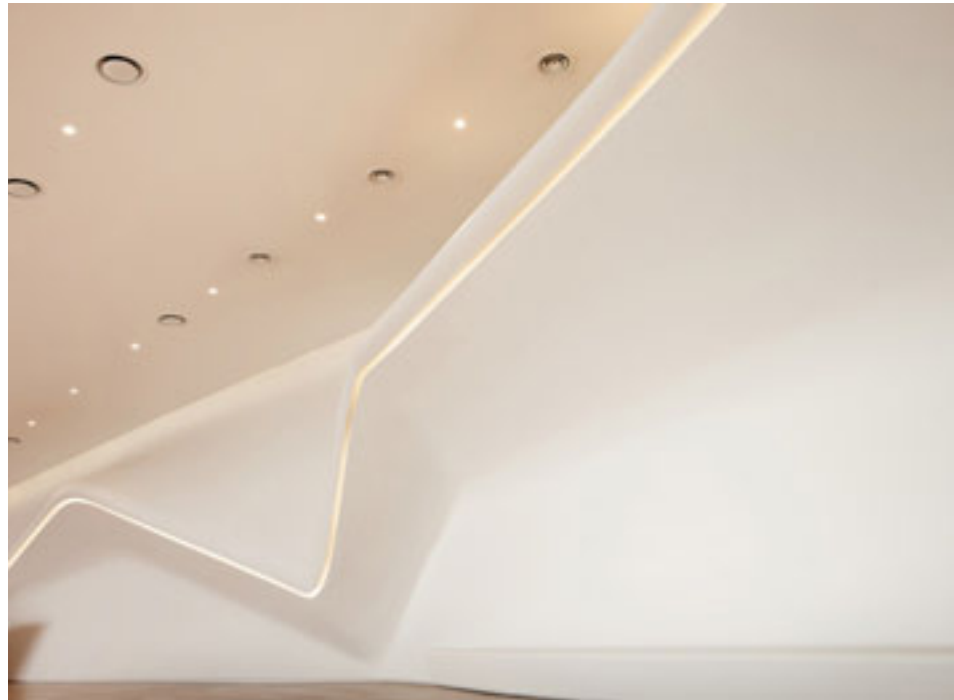

The walls in the Sky Lounge and columns and desk in the information centre of the Dongdaemun Design Plaza were created using the STARON<sup>®</sup> organic design line of Zaha Hadid Architects.



**SAMSUNG SDI**



## Cultural facilities

### Olympiastadion Berlin



The furniture and interior design of the visitor centre at the Olympic Stadium in Berlin was designed almost entirely in STARON®.

The milled-out stadium logo and the backlighting on the front side create a three-dimensional image for the viewer.

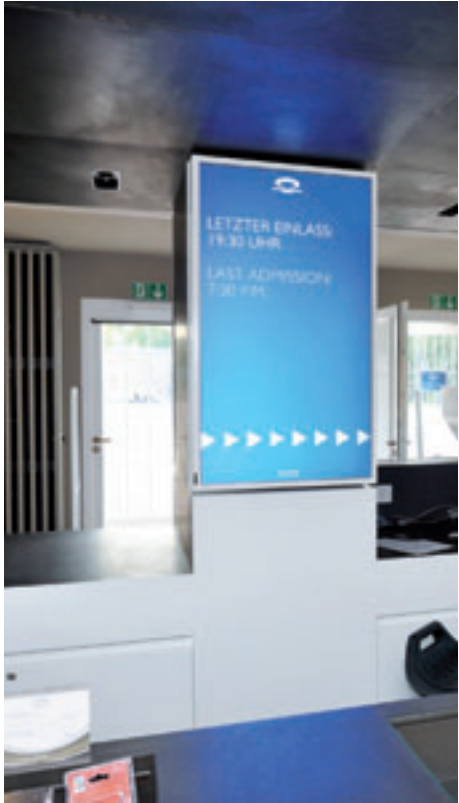

## Hotel

### Aspects

In hotels, STARON<sup>®</sup> offers guests a great welcome and the hotelier a presentable, durable, low-maintenance interior. Interior and furniture designs

made from STARON<sup>®</sup> are well-suited to the reception, the lobby, guest rooms and baths, public sanitary facilities, the hotel bar and the wellness areas.

### Hotel reception



## Hotel

### Guest rooms



A clear design has been selected for these guest rooms. LED lights set additional accents.



## Hotel

### Guest bathroom



Whether it be for the complete design of the bathroom, including washbasin, bathtub and wall design, or for individual shower tray and washbasin designs – STARON<sup>®</sup> integrates form and function for all applications.



SAMSUNG SDI

## Hotel

### Guest bathroom

The guest bathroom is the signature of the hotel, often giving an initial impression of the hotel as a whole and how it values its guests. STARON® affords individual washbasin and interior designs for this area.



## Hotel

### Wellness areas

STARON<sup>®</sup> adjusts itself to the ambient room temperature. Flowing, soft shapes and the agreeable tactile properties of the surfaces invite you to spend time and relax.

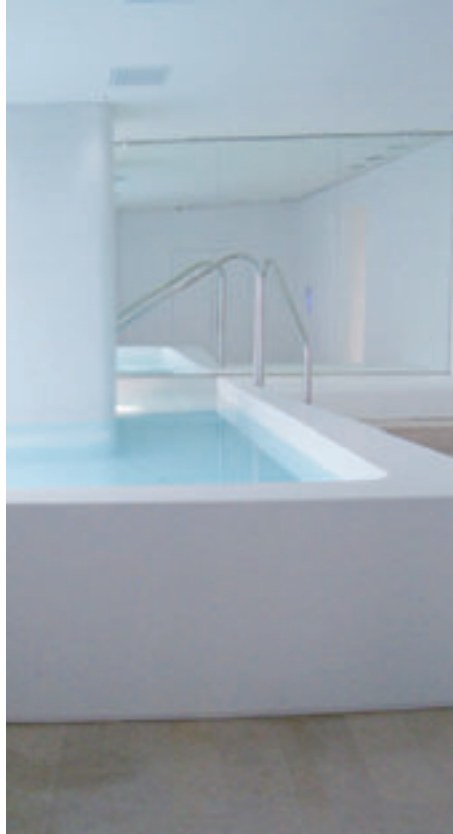

## Hotel

### Hotel bar

The hotel bar is the preferred place of recreation for late afternoons and evenings. Its furnishings are a reflection of the hospitality of the hotel. This hotel bar is a successful material mix of STARON® and natural stone.

STARON® is used for the counter covering and for the wall, floor, ceiling and furniture fronts. With individual lighting, STARON® absorbs the different colour shades, creating alternating moods.



## Gastronomy

### Aspects

From individual to system gastronomy – STARON® is perfect for generating a highly recognisable individual brand design with no limits set to creativity.

The product range simultaneously provides the theme for furnishing the restaurant.

The monolithic bar contrasts with the delicate STARON® wall cladding.



The bar unit is intended as a homage to 50s design.

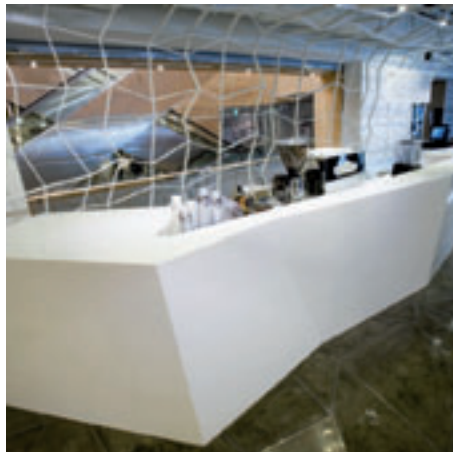

The STARON® table, counter and seating design winds through the restaurant like a lava flow of surface colour.





## Gastronomy

### Individual gastronomy



This STARON® counter unit suggests the narrow hull of a ship.



The integrated raised edge of the worktop prevents liquids from running into the dining area.



The bar units occupy the centres of the rooms.



Due to the light at its base, the counter appears to float. The stainless steel rods embedded into the tray slide prevent surface scratches.



## Gastronomy

### System gastronomy



Here STARON® was used to implement the corporate design of system gastronomy in the food counters, functional equipment and table furnishings.



SAMSUNG SDI

## Shopfitting

### Aspects

For shopfitting purposes, STARON® is ideal for an exclusive, neutral product presentation. STARON® has been applied successfully for interior and furniture design as well as for lighting and presentation elements. STARON® is used in exclusive single projects and in modular system design.

Coordinated forms and colours in corporate design offer a broad design spectrum for supermarkets and shopping centres, grocery, clothes, electronics and lifestyle shops, bookstores and pharmacies.



Both entire interior design concepts and elements of individual product presentations have been realised using STARON®.



## Shopfitting

Customer reception  
and service



SAMSUNG SDI

## Shopfitting

### Furniture functions

This STARON® countertop can be swivelled out when more room is required.

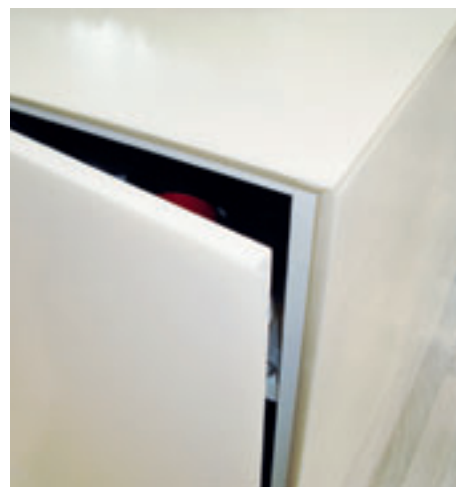

At second glance, the decorative STARON® cubic block turns out to be a practical storage space.

The functional elements and furniture systems in this hairdresser's shop are manufactured entirely from STARON®.



## Health care

### Aspects

In the health care sector, the high demands placed on hygiene and chemical resistance are the reasons for the diverse and tried-and-tested application of STARON® in the design of

reception units and workstations, baby washing and baby changing tables, laboratory and operation room facilities, patient rooms, and baths.

### Reception



A friendly reception has an important function, especially in hospitals.



### Workstations

The STARON® customer service points and workstations are furnished in an open, functional way.



### Patient baths



The baths of the patient rooms contain STARON® washbasins and sanitary furniture.



## Health care

### Maternity ward



The care facilities are individually designed with an extensive range of STARON® moulded parts.

### Dental practice



In this dental practice, the worktops and furniture fronts of the laboratory and hygienic facilities have been realised using STARON®.

### Operating room



The wall cladding of this operation room is fashioned in the form of reversible front-wall elements.

Technical functional units can be dismantled or expanded at any time.

# Furnishings and Designs

## Motor home, train and yacht interior finishing

### Aspects

STARON® has proven itself to be a reliable "travel companion" for road, rail and sea.

### Motor homes



Even the smallest niches can be functionally exploited using individual shapes.



### Passenger trains



**SAMSUNG**

**SAMSUNG SDI**

The on-board restaurant furnished with STARON® impresses with its coordinated colours and forms.



# Furnishings and Designs

## Motor home, train and yacht interior finishing

### Yacht furnishings



On the exterior, STARON<sup>®</sup> defies all weather conditions.

In the interior, STARON<sup>®</sup> dazzles with high-quality, detailed designs.



## Wall designs

### Aspects

The areas of application for STARON<sup>®</sup> are diverse and meet the highest demands. They range from transparent

partitions integrated in high-quality interior finishing to seamless wall cladding for hygiene and health care applications.



The homogeneity and formability of STARON<sup>®</sup> sheets allow for flexible wall designs in the form of a transparent network and a three-dimensionally formed partition.



SAMSUNG SDI

## Artistic and practical objects

### Aspects

STARON® material properties such as homogeneity, continuous colour structure, its ability to be processed in filigree detail, and its translucence

and sublimation possibilities continuously inspire architects and designers with new ideas and areas of application.

Homogenous



Colour-compatible



Flexible in shape



Delicate

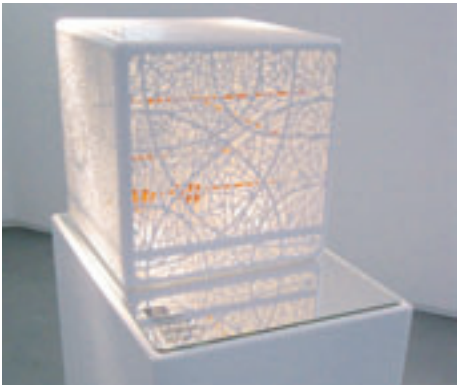

Sublimated

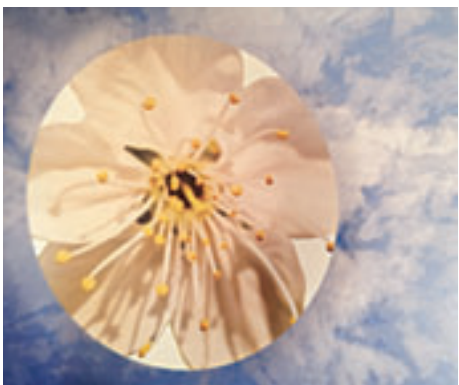

Translucent

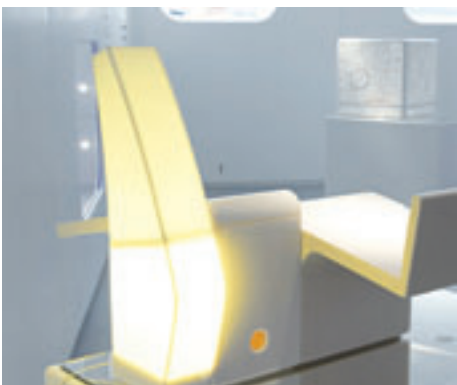



**SAMSUNG SDI**

## **3 Product Overview**

STARON<sup>®</sup> sheets  
STARON<sup>®</sup> moulded parts and  
service contact  
STARON<sup>®</sup> product descriptions

STARON<sup>®</sup> sheet colours 2015  
STARON<sup>®</sup> adhesive  
Manufactured by Samsung  
Manufactured by fabricator





## STARON<sup>®</sup> sheets

### STARON<sup>®</sup> sheet colours

Samsung manufactures STARON<sup>®</sup> sheets in over 140 individual colours for international use with a wide variety of regional demands on design, colour harmony and areas of application. The colour palette described in this documentation reflects current European trends. The colours may require various levels of care. Dark or rich colours are more sensitive and require more maintenance.

The colour illustrations may deviate for printing-related reasons from the original colour of the STARON<sup>®</sup> sheets. Some colours contain metallic particles. They may create different reflections depending on the point of view.

For colour and material collages, please order your product sample at your local supplier or via the STARON<sup>®</sup> hotline.

### Technical information

Colour nuances:  
Minor colour deviations may occur in manufacturing the production batches due to material- and manufacturing-related reasons. These nuances in colour do not represent defects and do not constitute a reason for complaint.

This fact may also have to be accounted at the at the planning and project management stage by implementing design solutions. It is recommended to consult the fabrication plant for manufacturing and ordering materials.

### Sheet sizes

Sheet size (mm)		
Thickness	Length	Width
6	2500	760
12	3680	760

Not all colours are available in 6 mm or are only available in special ordering quantities and have special delivery times.

Please enquire the minimum order quantity situation prior to the beginning of your planning.

### Tempest<sup>®</sup>

Tempest<sup>®</sup> is an exclusive mineral material with a high-quality three-dimensional optical impression. The material consists of natural minerals such as fillers, acrylic binding agent and crystalline particles.

The fabrication options are different from those of other STARON<sup>®</sup> sheets. Thermoforming Tempest<sup>®</sup> sheets is only possible to a limited extent.

### Colour development

We are happy to develop a purchase quantity of 100 sheets with our

customers for individual special colours.

### Special dimensions

In order to optimise cutting and reduce costs in project management, we are also happy to offer other sheet lengths on request.



**SAMSUNG SDI**

## STARON<sup>®</sup> moulded parts and service contact

### STARON<sup>®</sup> moulded parts

The STARON<sup>®</sup> moulded part models illustrated are intended to represent a selection from the extensive product range of STARON<sup>®</sup> production and processing. The high processing flexibility of STARON<sup>®</sup> sheets together with its thermoplastic properties and the almost invisible adhesive allow for the realisation of individual moulded parts for private and commercial use in interior and structural architecture.



### Service contact



#### Customer service:

Samsung Chemical Europe GmbH

Phone: +49 6196 66 74 34

E-mail: [architect@samsung.com](mailto:architect@samsung.com)

[www.staron-samsung.com](http://www.staron-samsung.com)



**SAMSUNG SDI**



## STARON<sup>®</sup> product descriptions

### STARON<sup>®</sup> Mineral material sheets

STARON<sup>®</sup> mineral material products, manufactured by Samsung Chemical, are styrene-free, acrylic-based solid sheets and moulded parts with mineral fillers. STARON<sup>®</sup> sheets and moulded parts can be glued together without seams using STARON<sup>®</sup> methyl methacrylate adhesive. Material processing and assembly are executed according to the specifications and recommendations of the manufacturer.

Specific and purchasing data

Design in

Colour name: (e.g. Pebble Ice)

Colour code: (e.g. PI 811)

Sheet thickness: (e.g. 12 mm)



### STARON<sup>®</sup> Mineral material moulded parts

1. STARON<sup>®</sup> moulded parts, manufactured in a closed casting process by Samsung:

Overflow: with/without

Moulded part colour:

Dimensions in mm: LxWxD

Installation version:

seamless undermount/worktop/  
installation

Model number:

2. Deep-drawn STARON<sup>®</sup> moulded parts assembled from 12-mm STARON<sup>®</sup> sheets:

Overflow: with/without

Sheet colour:

(colour name/code)

Dimensions in mm: LxWxD

Installation version:

seamless undermount/worktop/  
installation

Model number:

3. STARON<sup>®</sup> moulded parts assembled, deep-drawn and glued from 12-mm STARON<sup>®</sup> sheets:

Overflow: with/without

Sheet colour:

(colour name/code)

Dimensions in mm: LxWxD

Installation version:

seamless undermount/worktop/  
installation

Model number:

### STARON<sup>®</sup> adhesive

STARON<sup>®</sup> methyl methacrylate adhesive is a 2-component adhesive for decorative STARON<sup>®</sup> mineral sheets and moulded parts.

STARON<sup>®</sup> methyl methacrylate adhesive adheres to all mineral materials, is resistant to discolouration and waterproof. Fabricating STARON<sup>®</sup> with this adhesive is a condition for providing warranties.



**SAMSUNG SDI**

## STARON<sup>®</sup> sheet colours 2015

### Solid

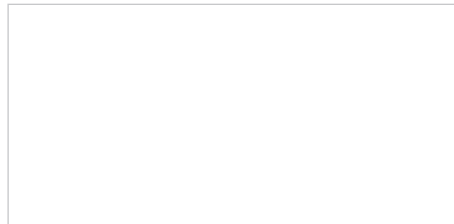

Quasar White SQ019

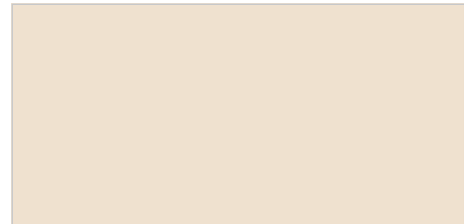

Natural SV041

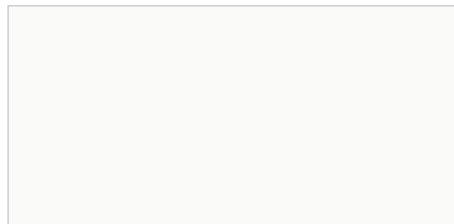

Pure White SP016

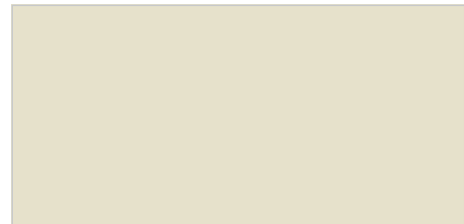

Tusk ST015

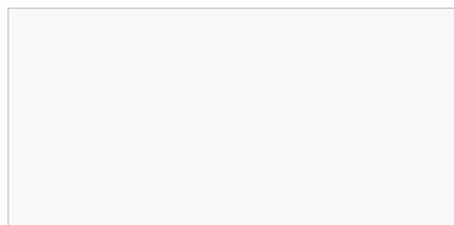

Bright White BW010

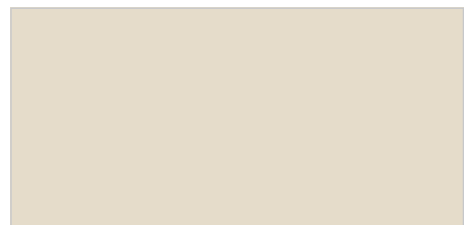

Ivory SI040

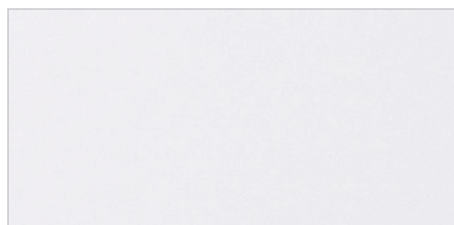

Dazzling White SD001

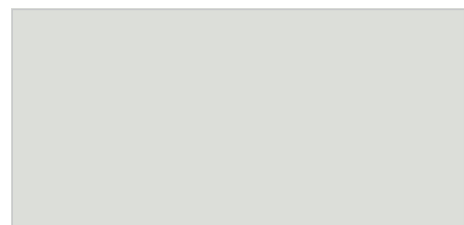

Fog SF020



Pearl SP011

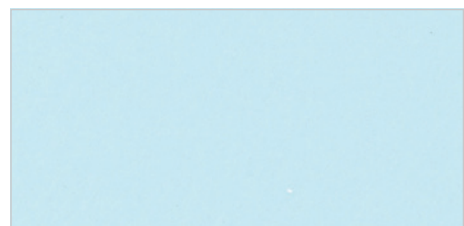

Cool Mint SC063 ▲



- Sheets created using recycled materials
  - Colours with metallic particles which exhibit different reflections depending on point of view
  - ▲ Colours requiring higher maintenance
- The colour illustrations may deviate from the original sheet colours for printing-related reasons.  
Please use the STARON<sup>®</sup> sample for colour and material selection.



**SAMSUNG SDI**

## STARON<sup>®</sup> sheet colours 2015

### Solid

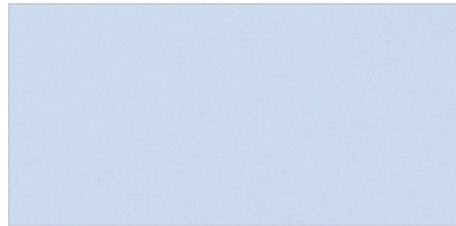

Powder Blue SP063 ▲



Mist SM022

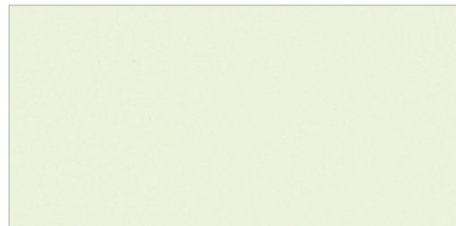

Blonde SB043 ▲

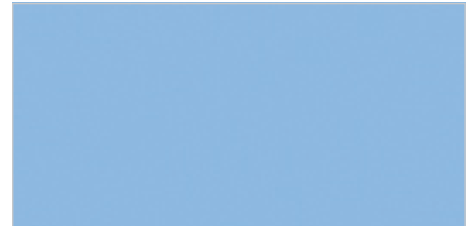

Placid SP062 ▲



Sunflower SS042 (N)

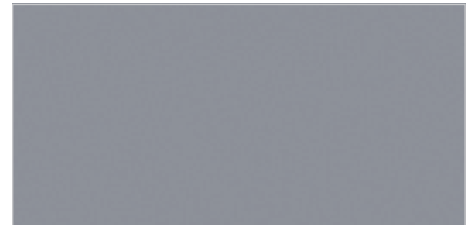

Bliss SB022 ▲



California Poppy SC052 (N) ▲

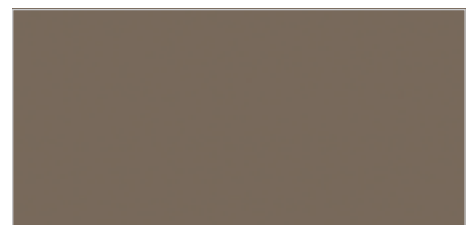

Serene SS023 ▲



Univers SU053 (N) ▲

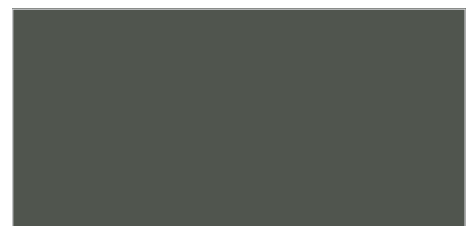

Steel ST023 ▲



- Sheets created using recycled materials
  - Colours with metallic particles which exhibit different reflections depending on point of view
  - ▲ Colours requiring higher maintenance
- The colour illustrations may deviate from the original sheet colours for printing-related reasons.  
Please use the STARON<sup>®</sup> sample for colour and material selection.

## STARON® sheet colours 2015

### Solid



Eggplant SV037 ▲



Onyx ON095 ▲



Iris SI056 ▲



- Sheets created using recycled materials
  - Colours with metallic particles which exhibit different reflections depending on point of view
  - ▲ Colours requiring higher maintenance
- The colour illustrations may deviate from the original sheet colours for printing-related reasons.  
Please use the STARON® sample for colour and material selection.



**SAMSUNG SDI**

## STARON<sup>®</sup> sheet colours 2015

### Sanded

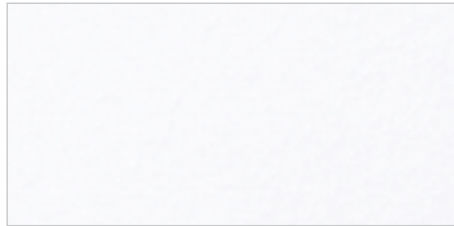

Icicle SI414

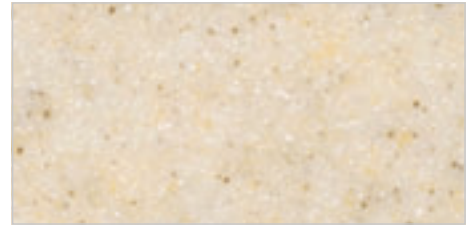

Sahara SS440 ●



Birch SB412



Gold Dust SG441 ●

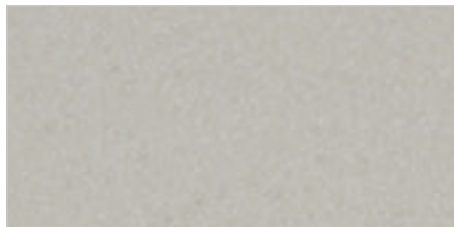

Stratus SS418



Cornmeal SC433



White Pepper WP410



Papyrus SP474



Cream SM421 ●

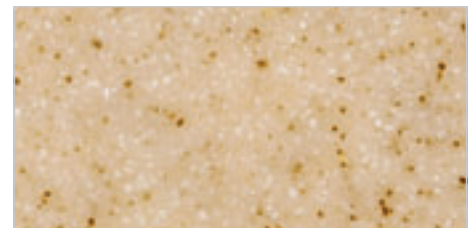

Oatmeal SO446



- Sheets created using recycled materials
  - Colours with metallic particles which exhibit different reflections depending on point of view
  - ▲ Colours requiring higher maintenance
- The colour illustrations may deviate from the original sheet colours for printing-related reasons.  
Please use the STARON<sup>®</sup> sample for colour and material selection.

## STARON® sheet colours 2015

### Sanded

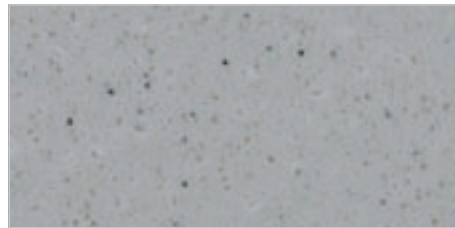

Heron SH428

New

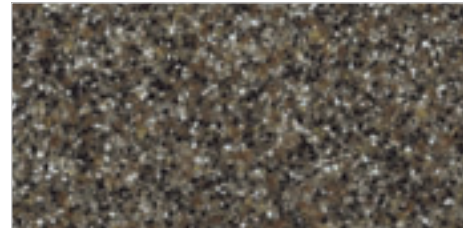

Mocha SM453 ▲



Vermillion SV430



Clay SC475

New

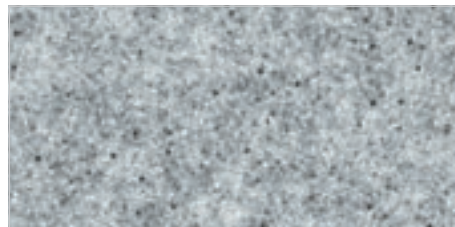

Sanded Grey SG420 ●

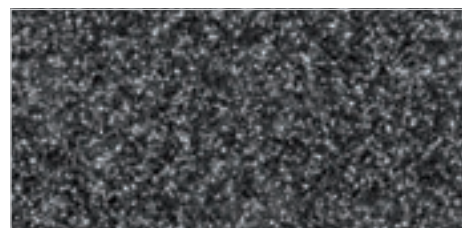

Dark Nebula DN421 ●

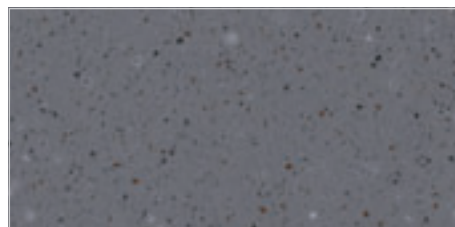

Tundra ST482 ▲

New



Sanded Onyx SO423 ● ▲



- Sheets created using recycled materials
  - Colours with metallic particles which exhibit different reflections depending on point of view
  - ▲ Colours requiring higher maintenance
- The colour illustrations may deviate from the original sheet colours for printing-related reasons.  
Please use the STARON® sample for colour and material selection.



**SAMSUNG SDI**

## STARON<sup>®</sup> sheet colours 2015

### Aspen

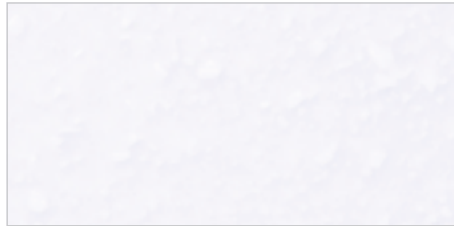

Glacier AG612

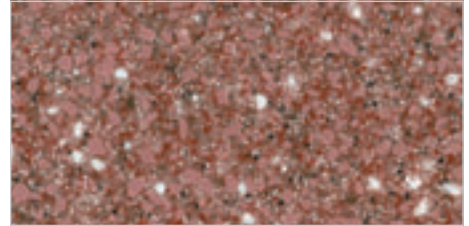

Lava AL650

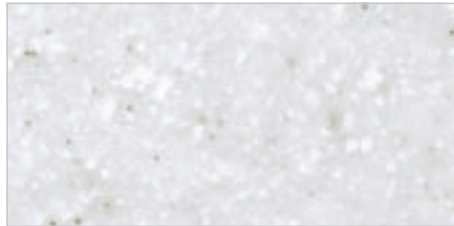

Snow AS610 ●

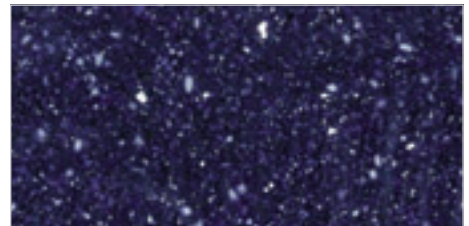

Sky AS670 ▲

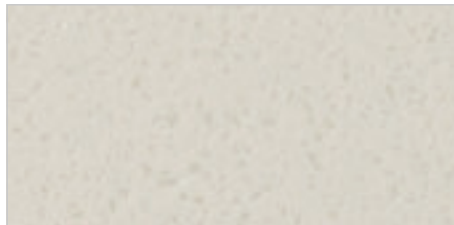

Lily AL645

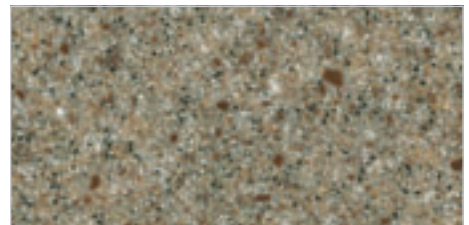

Brown AB632 ●

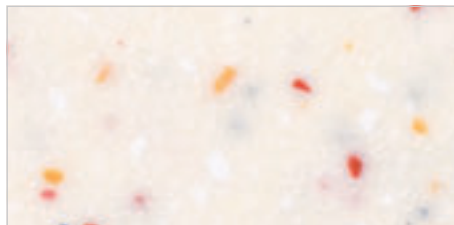

Fiesta AF611

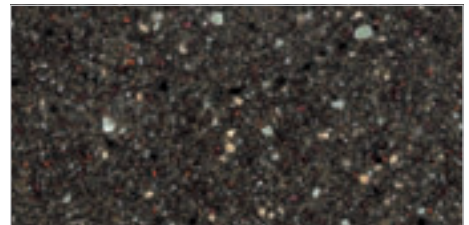

Mine AM633 ▲

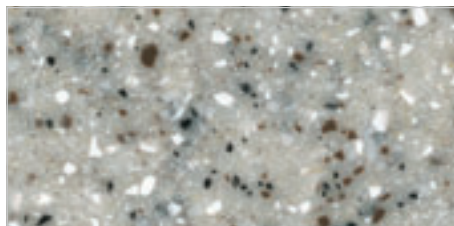

Pepper AP640



- Sheets created using recycled materials
  - Colours with metallic particles which exhibit different reflections depending on point of view
  - ▲ Colours requiring higher maintenance
- The colour illustrations may deviate from the original sheet colours for printing-related reasons.  
Please use the STARON<sup>®</sup> sample for colour and material selection.

## STARON® sheet colours 2015

### Pebble

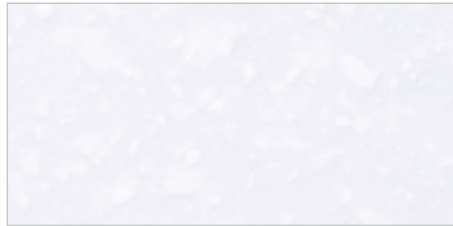

Ice PI811

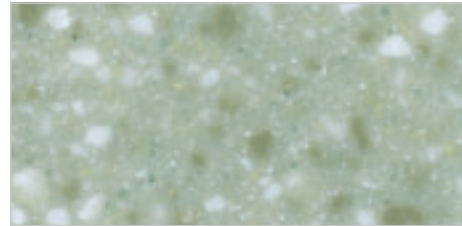

Aqua PA860

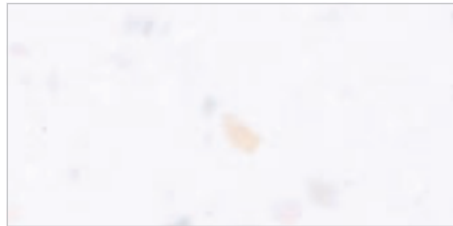

Swan PS813

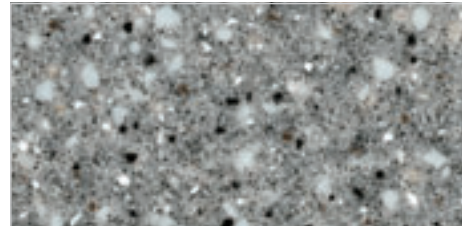

Pebble Grey PG810 ●



Fresco PF844

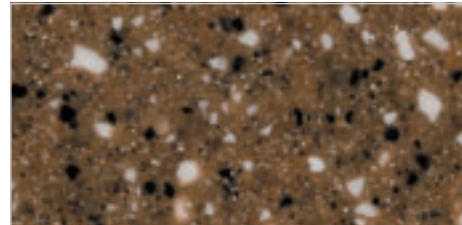

Copper PC851 ● ▲



Saratoga PS820 ●

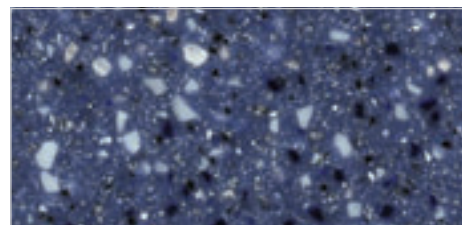

Blue PB870 ▲

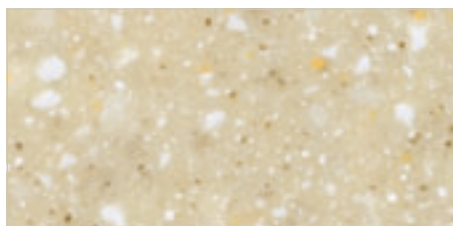

Gold PG840 ●

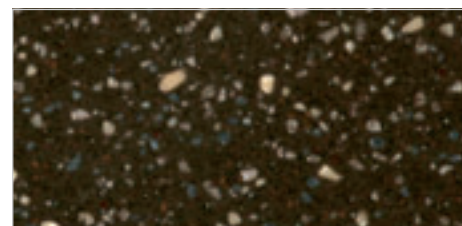

Terrain PT857 ▲



- Sheets created using recycled materials
  - Colours with metallic particles which exhibit different reflections depending on point of view
  - ▲ Colours requiring higher maintenance
- The colour illustrations may deviate from the original sheet colours for printing-related reasons.  
Please use the STARON® sample for colour and material selection.



**SAMSUNG SDI**



## STARON<sup>®</sup> sheet colours 2015

### Pebble

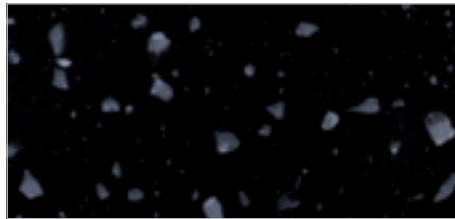

Ebony PE814 ● ▲

### Metallic

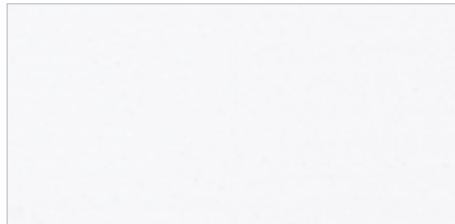

Yukon EY510 ■



Sleek Silver ES581 ■ ▲

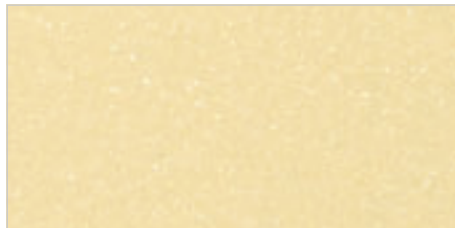

Beach EB545 ■



Galaxy EG595 ■ ▲



Satin Gold ES558 ■ ▲



- Sheets created using recycled materials
  - Colours with metallic particles which exhibit different reflections depending on point of view
  - ▲ Colours requiring higher maintenance
- The colour illustrations may deviate from the original sheet colours for printing-related reasons.  
Please use the STARON<sup>®</sup> sample for colour and material selection.



**SAMSUNG SDI**

## STARON® sheet colours 2015

### Quarry



Oyster T0310 ●

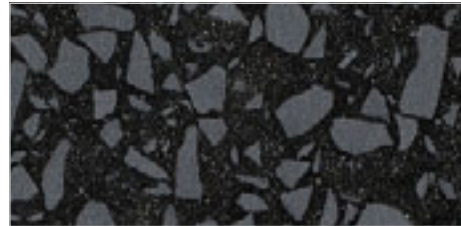

Minette QM289 ■▲



Starred QS287 ■▲

### Earthen

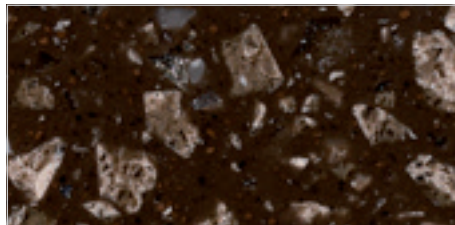

Bark QL257 ▲

### Mosaic



Dalmatian QD212



Black Bean QB299 ▲



- Sheets created using recycled materials
  - Colours with metallic particles which exhibit different reflections depending on point of view
  - ▲ Colours requiring higher maintenance
- The colour illustrations may deviate from the original sheet colours for printing-related reasons.  
Please use the STARON® sample for colour and material selection.



**SAMSUNG SDI**

## STARON® sheet colours 2015

### Tempest®



Polar FP111

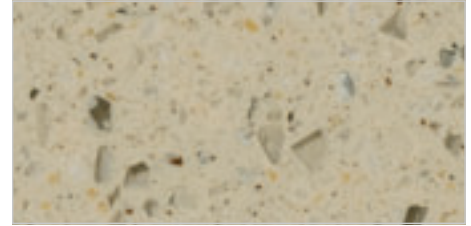

Genesis FG174



Pinnacle FP112

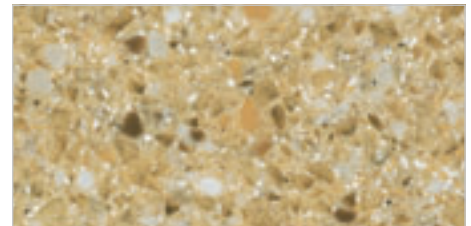

Rattan FR124



Meteor FM111

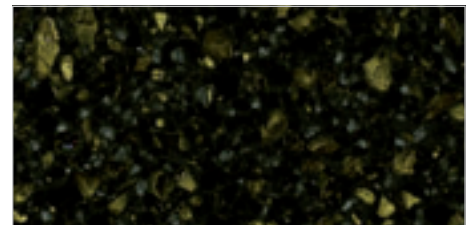

Gold Leaf FG196 ▲



Peak FP100

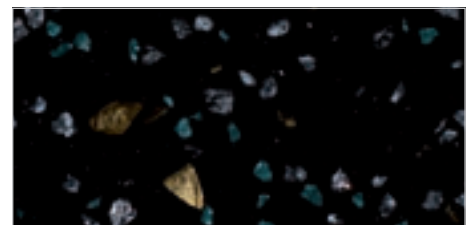

Dazzle FD191 ▲



Silvercloud FS122

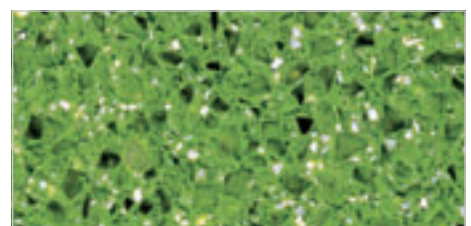

Spearmint FS164



- Sheets created using recycled materials
  - Colours with metallic particles which exhibit different reflections depending on point of view
  - ▲ Colours requiring higher maintenance
- The colour illustrations may deviate from the original sheet colours for printing-related reasons.  
Please use the STARON® sample for colour and material selection.

## STARON® sheet colours 2015

### Tempest®

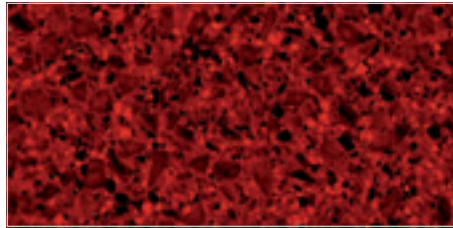

Paprika FP136 ▲

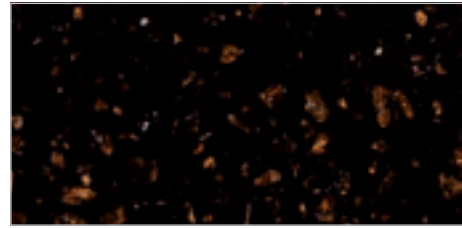

Shimmer FR148 ▲

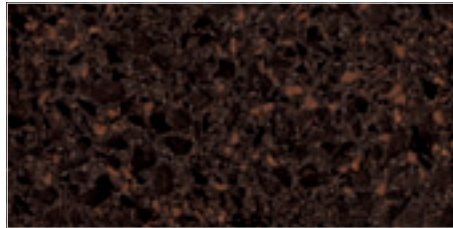

Coffee Bean FC158 ▲

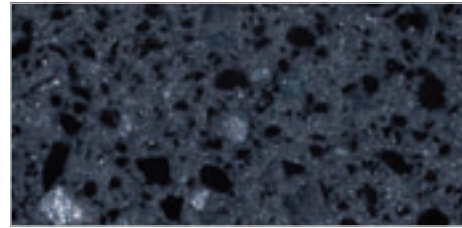

Caviar FC188 ▲

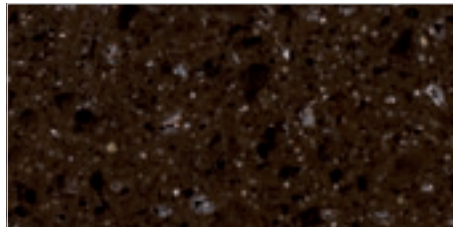

Adamantine FA159 ▲

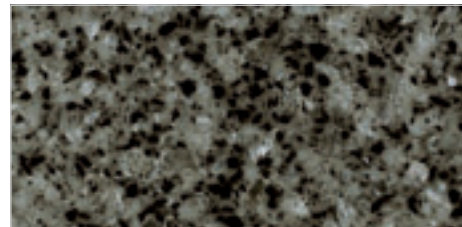

Zenith FZ184

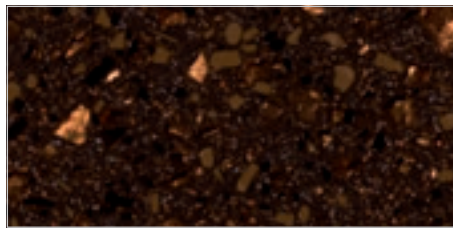

Blaze FB147 ▲



Starfire FS198 ▲



- Sheets created using recycled materials
  - Colours with metallic particles which exhibit different reflections depending on point of view
  - ▲ Colours requiring higher maintenance
- The colour illustrations may deviate from the original sheet colours for printing-related reasons.  
Please use the STARON® sample for colour and material selection.



**SAMSUNG SDI**

## STARON<sup>®</sup> adhesive

### Sheet colour

Solid Pure white  
Mosaic Dalmatian  
Tempest<sup>®</sup> Polar  
Solid Dazzling White  
Solid Fog  
Solid Pearl  
Solid Natural  
Solid Tusk  
Sanded Stratus  
Quarry Oyster  
Tempest<sup>®</sup> Silvercloud  
Sanded Cornmeal  
Sanded White Pepper  
Aspen Snow  
Sanded Mocha  
Pebble Grey  
Sanded Gold Dust  
Sanded Vermillion  
Aspen Brown  
Pebble Gold  
Solid Steel  
Quarry Starred  
Sanded Oatmeal  
Tempest<sup>®</sup> Rattan  
Sanded Grey  
Sanded Sahara  
Pebble Saratoga  
Pebble Aqua  
Metallic Beach  
Sanded Icicle  
Aspen Lily  
Sanded Tundra  
Sleek Silver  
Sanded Birch  
Sanded Cream  
Aspen Glacier  
Aspen Fiesta  
Pebble Ice  
Metallic Yukon  
Pebble Swan  
Tempest<sup>®</sup> Meteor  
Tempest<sup>®</sup> Pinnacle  
Pebble Terrain  
Earthen Bark  
Tempest<sup>®</sup> Adamantine  
Tempest<sup>®</sup> Blaze  
Tempest<sup>®</sup> Coffee Bean

### Adhesive colour

Pure white  
Pure white  
Pure white  
Dazzling White  
Dazzling White  
Pearl  
Pearl  
Pearl  
Pearl  
Pearl  
Pearl  
A/Snow  
A/Snow  
A/Snow  
A/Grey  
A/Grey  
S/Gold Dust  
S/Gold Dust  
S/Gold Dust  
S/Gold Dust  
Steel  
Steel  
S/Oatmeal  
S/Oatmeal  
S/Sahara  
S/Sahara  
S/Sahara  
S/Sahara  
S/Sahara  
S/Sahara  
S/Icicle  
S/Icicle  
S/Tundra  
S/Tundra  
A/Glacier  
A/Glacier  
A/Glacier  
A/Glacier  
A/Glacier  
A/Glacier  
P/Swan  
P/Swan  
P/Swan  
P/Terrain  
P/Terrain  
P/Terrain  
P/Terrain



## STARON<sup>®</sup> adhesive

Sheet colour	Adhesive colour
Solid Onyx	S/Onyx
Sanded Onyx	S/Onyx
Pebble Ebony	S/Onyx
Tempest <sup>®</sup> Dazzle	S/Onyx
Tempest <sup>®</sup> Shimmer	S/Onyx
Tempest <sup>®</sup> Starfire	S/Onyx
Solid Quasar White	Quasar White
Solid Bright White	Bright White
Solid Ivory	So/Ivory
Solid Cool Mint	Cool Mint
Solid Powder Blue	Powder Blue
Solid Blonde	Blonde
Solid Sunflower (N)	Sunflower (N)
Solid California Poppy (N)	California Poppy (N)
Solid Univers (N)	Univers (N)
Solid Mist	Mist
Solid Placid	Placid
Solid Bliss	Bliss
Solid Serene	Serene
Solid Eggplant	Eggplant
Solid Iris	Iris
Sanded Papyrus	S/Papyrus
Sanded Heron	S/Heron
Sanded Clay	S/Clay
Sanded Dark Nebula	S/Dark Nebula
Aspen Pepper	A/Pepper
Aspen Lava	A/Lava
Aspen Sky	A/Sky
Aspen Mine	A/Mine
Pebble Fresco	P/Fresco
Pebble Copper	P/Copper
Pebble Blue	P/Blue
Metallic Satin Gold	M/Satingold
Metallic Galaxy	M/Galaxy
Quarry Minette	Q/Minette
Mosaic Black Bean	Mo/BlackBean
Tempest <sup>®</sup> Peak	T/Peak
Tempest <sup>®</sup> Genesis	T/Genesis
Tempest <sup>®</sup> Gold Leaf	T/Gold leaf
Tempest <sup>®</sup> Spearmint	T/Spearmint
Tempest <sup>®</sup> Paprika	T/Paprika
Tempest <sup>®</sup> Caviar	T/Caviar
Tempest <sup>®</sup> Zenith	T/Zenith



**SAMSUNG SDI**



### STARON<sup>®</sup> adhesive

In order to glue STARON<sup>®</sup> sheets and moulded parts in their different colours, colour-coordinated STARON<sup>®</sup> adhesives are used. The table provides a recommended assignment of sheet colour to STARON<sup>®</sup> adhesive.

# Product Overview

Manufactured by Samsung

**STARON®**  
Kitchen sinks\*

**A2321**

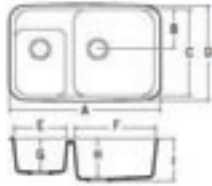

- A 30-13/16" (804mm)
- B 9-13/16" (224mm)
- C 19-1/4" (490mm)
- D 21-9/16" (548mm)
- E 11-5/16" (297mm)
- F 17-9/16" (446mm)
- G 7-1/2" (191mm)
- H 9" (229mm)
- I 9-5/8" (244mm)

**A2311**

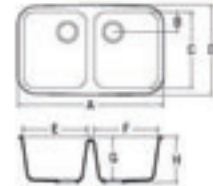

- A 31-1/4" (794mm)
- B 4-15/16" (118mm)
- C 16-9/16" (420mm)
- D 18-25/16" (481mm)
- E 13-1/16" (340mm)
- F 13-1/16" (340mm)
- G 9-1/4" (235mm)
- H 9-15/16" (250mm)

**A2341**



- A 34-7/8" (885mm)
- B 8-3/8" (213mm)
- C 16-3/4" (426mm)
- D 19-1/8" (486mm)
- E 10" (254mm)
- F 21" (533mm)
- G 5" (127mm)
- H 7-1/2" (191mm)
- I 9-1/16" (236mm)

**STARON®**  
Washbasins\*

**A3181**

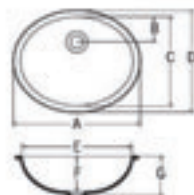

- A 18-3/16" (462mm)
- B 3-11/16" (94mm)
- C 13-1/4" (336mm)
- D 14-13/16" (370mm)
- E 16-5/8" (422mm)
- F 5-1/2" (139mm)
- G 6-1/8" (156mm)



# Product Overview

Manufactured by Samsung

**STARON®  
Washbasins\***

**A3211**

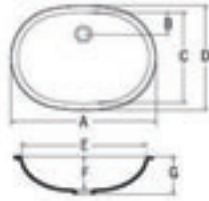

- A 21-9/16" (548mm)
- B 2-5/8" (66mm)
- C 14" (356mm)
- D 15-9/16" (398mm)
- E 20" (508mm)
- F 6-1/8" (156mm)
- G 6-13/16" (173mm)

**STARON®  
Single sinks\***

**A1231**

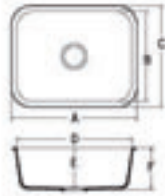

- A 23-5/16" (592mm)
- B 18-5/8" (472mm)
- C 19" (482mm)
- D 20-13/16" (532mm)
- E 7-3/8" (187mm)
- F 7-5/16" (202mm)

**A1181**

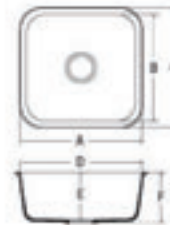

- A 18-1/8" (460mm)
- B 15-3/4" (400mm)
- C 18-1/8" (460mm)
- D 15-3/4" (400mm)
- E 8-3/16" (208mm)
- F 8-7/8" (225mm)

**A1121**

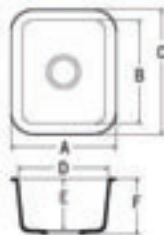

- A 12-13/16" (326mm)
- B 14" (356mm)
- C 16-3/8" (416mm)
- D 18-3/8" (466mm)
- E 6-1/2" (165mm)
- F 7-1/16" (190mm)

**A1131**

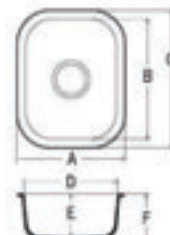

- A 13-7/16" (341mm)
- B 15-3/4" (400mm)
- C 18-1/8" (460mm)
- D 11-1/16" (281mm)
- E 5-1/4" (133mm)
- F 5-7/8" (148mm)



**SAMSUNG SDI**



Manufactured by fabricator

## Undermount oval

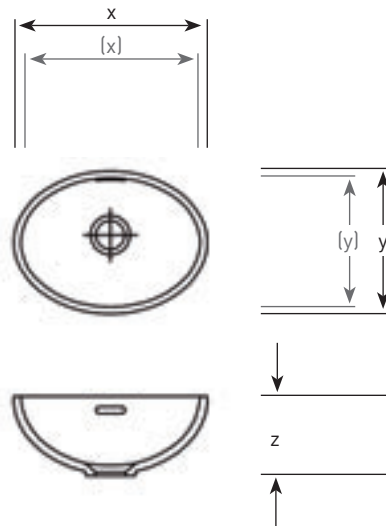

Available in the following dimensions:

- WO 0275 U  
291(270) x 216(195) x 104
- WO 0315 U  
334(310) x 249(225) x 117
- WO 0365 U  
381(360) x 281(257) x 128
- WO 0415 U  
434(412) x 322(299) x 132
- WO 0465 U  
484(462) x 366(344) x 130
- WO 0490 U  
514(492) x 409(387) x 130
- WO 0515 U  
542(520) x 398(376) x 130
- WO 0585 U  
600(580) x 412(390) x 135

# Product Overview

Manufactured by fabricator

## Undermount round

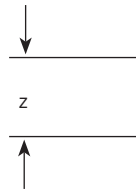
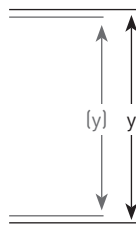
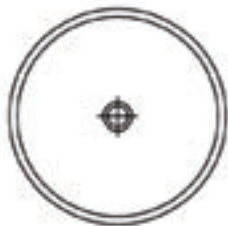
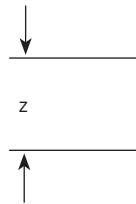
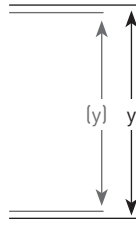

Available in the following dimensions:

- WR 0315 U  
338(318) x 128
- WR 0365 U  
388(368) x 139
- WR 445 U  
468(446) x 144
  
- WK 0416 U  
450(416) x 150 (138)



**SAMSUNG SDI**

Manufactured by fabricator

## Undermount angular

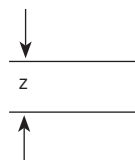
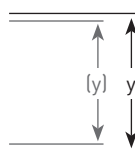
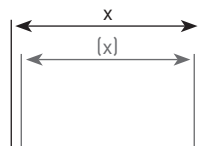
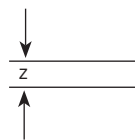
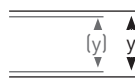
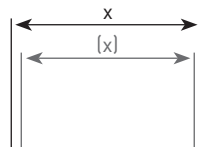
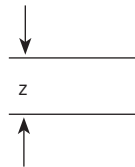
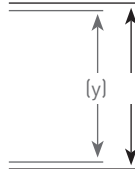
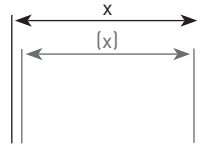

Available in the following dimensions:

- WE 0400 U  
400(374) x 328(304) x 133

- WE 0500 U  
500(476) x 350(326) x 128

- WE 0600 U  
600(574) x 326(350) x 128

- WE 0800 U  
800(762) x 350(326) x 133

- WE 1200 U  
1200(1146) x 400(376) x 133

- WEW 0515 U  
Width/inside 500–1476  
Depth 375 (351)  
Height 150 (138)  
Variable width

Manufactured by fabricator

## Undermount angular

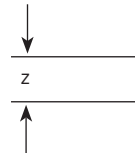
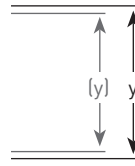
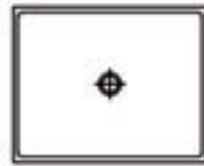
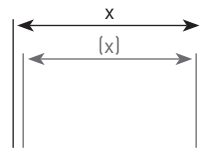

Available in the following dimensions:

- WEB 0515 U  
Width/inside 500-1476  
Depth 419 (390)  
Height 112 (100)  
Variable width

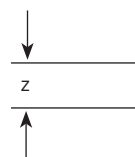
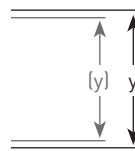
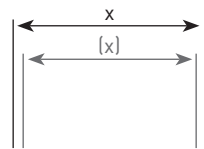

- WES 0515 U  
Width/inside 500-1216  
Depth 384 (360)  
Height 138 (126)  
Variable width



SAMSUNG SDI

Manufactured by fabricator

## Undermount angular

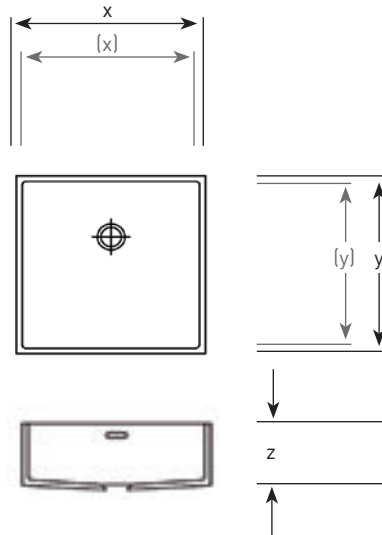

Available in the following dimensions:

- WE 0404 U  
400(376) x 400(376) x 138
- WE 0464 U  
462(438) x 462(438) x 138
- WE 0723 U  
726(702) x 350(326) x 138
- WE 0743 U  
745(721) x 375(351) x 138
- WE 1103 U  
1100(1076) x 350(326) x 138
- WE 1224 U  
1225(1201) x 425(401) x 138
- WE 4003 U  
400(376) x 350(326) x 138
- WE 5003 U  
500(476) x 350(326) x 138
- WE 5443 U  
544(520) x 379(355) x 138
- WE 5753 U  
575(551) x 475(451) x 138
- WE 6043 U  
604(580) x 350(326) x 138
- WE 6224 U  
622(598) x 462(438) x 138
- WE 6754 U  
975(651) x 425(401) x 138

Manufactured by fabricator

## Undermount angular

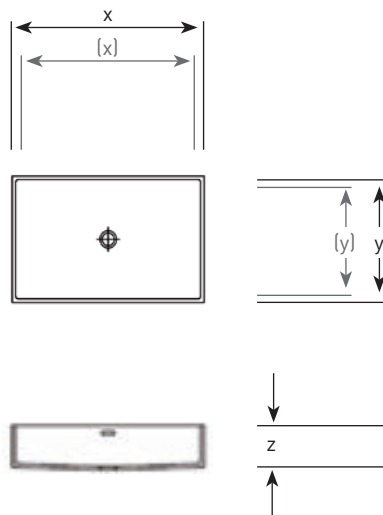

Available in the following dimensions:

- WE 5754 U  
575(551) x 475(451) x 138
- WE 8003 U  
800(776) x 350(326) x 138
- WE 6754 U  
975(651) x 425(401) x 138

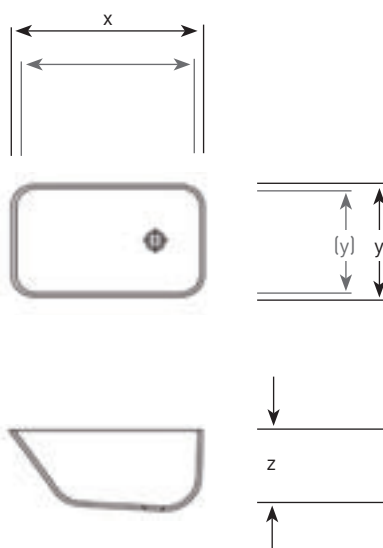

- BW 0600 U  
600(573) x 370(346) x 249
- BW 0750 U  
772(746) x 420(396) x 232
- BW 0800 U  
822(795) x 420(396) x 297



**SAMSUNG SDI**

Manufactured by fabricator

## Worktop oval

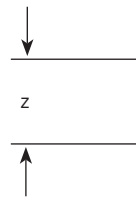
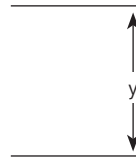
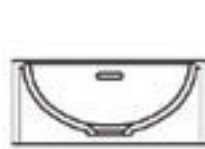
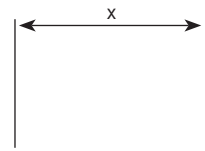

Available in the following dimensions:

- WO 0275 oA  
330 x 255 x 140
- WO 0315 oA  
370 x 285 x 160
- WO 0365 oA  
420 x 317 x 160
- WO 0415 oA  
471 x 359 x 160
- WO 0465 oA  
522 x 404 x 160
- WO 0490 oA  
552 x 447 x 160
- WO 0515 oA  
580 x 160
- WO 0585 oA  
640 x 450 x 170

# Product Overview

Manufactured by fabricator

## Worktop round

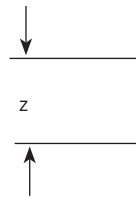
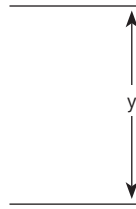
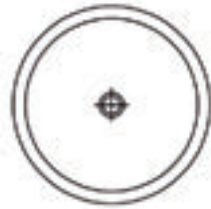

Available in the following dimensions:

- WR 0315 oA  
378 x 160
- WR 0365 oA  
436 x 170
- WR 0445 oA  
506 x 180

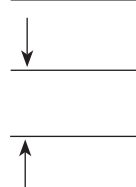
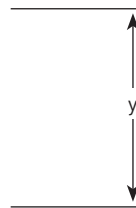
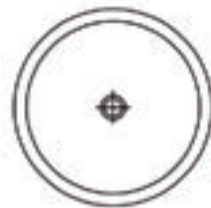

- WK 0450 oA  
476 x 170





Manufactured by fabricator

## Worktop angular

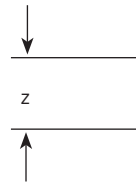
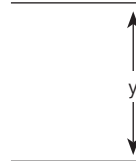
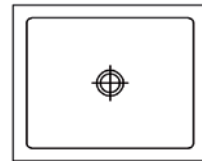
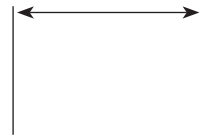

Available in the following dimensions:

- WE 0400 oA  
434 x 364 x 170

- WE 0500 oA  
534 x 386 x 170

- WE 0600 oA  
634 x 386 x 170

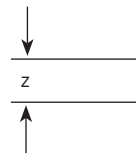

- WE 0800 oA  
828 x 386 x 170

- WE 1200 oA  
1220 x 436 x 170

# Product Overview

Manufactured by fabricator

## Worktop angular

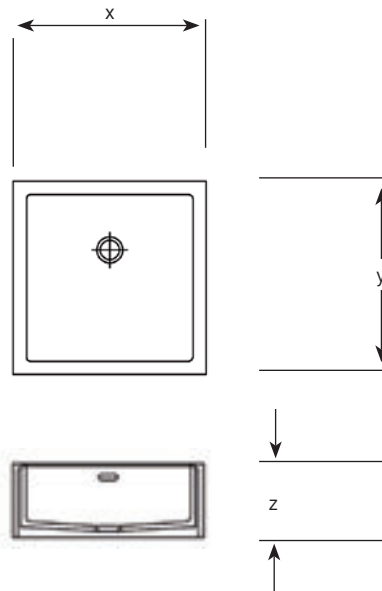

Available in the following dimensions:

- WE 0404 oA  
436 x 436 x 170
- WE 0464 oA  
498 x 498 x 170
- WE 0723 oA  
762 x 386 x 170
- WE 0744 oA  
781 x 411 x 170
- WE 1103 oA  
1136 x 386 x 170
- WE 1224 oA  
1261 x 461 x 170



**SAMSUNG SDI**

Manufactured by fabricator

## Worktop angular

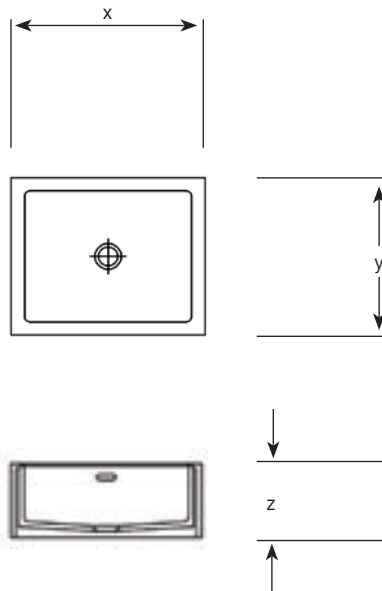

Available in the following dimensions:

- WE 5003 oA  
536 x 386 x 170
- WE 5443 oA  
580 x 415 x 170
- WE 5754 oA  
611 x 511 x 170
- WE 6003 oA  
636 x 386 x 170
- WE 6044 oA  
640 x 386 x 170
- WE 6224 oA  
658 x 498 x 170
- WE 6751 oA  
711 x 461 x 170
- WE 6751 oA  
711 x 461 x 170
- WE 8001 oA  
836 x 386 x 170



# Product Overview

Manufactured by fabricator

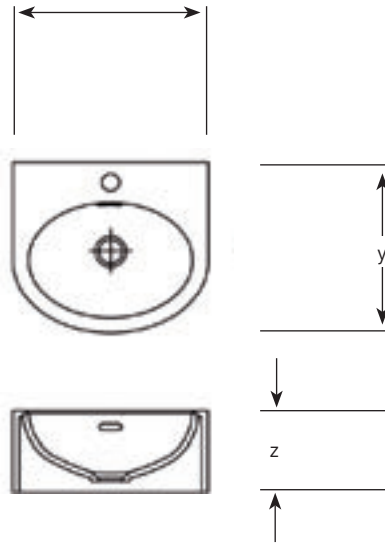

Available in the following dimensions:

- WO 0275 mA  
305 x 140
- WO 0315 mA  
370 x 335 x 160
- WO 0365 mA  
420 x 367 x 160
- WO 0415 mA  
472 x 409 x 160
- WO 0465 mA  
522 x 454 x 160
- WO 0490 mA  
552 x 497 x 160
- WO 0515 mA  
580 x 486 x 160
- WO 0585 A  
640 x 500 x 170



**SAMSUNG SDI**

Manufactured by fabricator

**Worktop  
round  
with tap ledge**

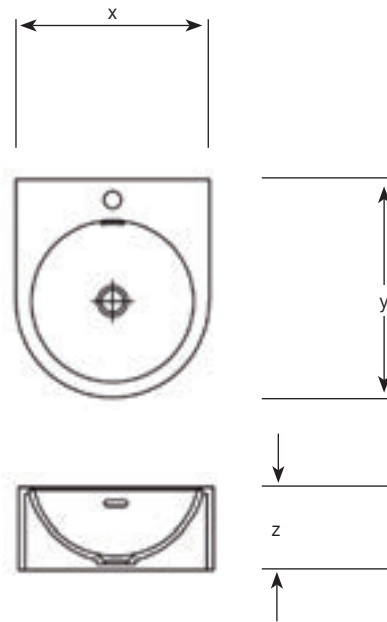

Available in the following dimensions:

- WR 0315 mA  
378 x 428 x 160
- WR 0365 mA  
436 x 482 x 170
- WR 0445 mA  
506 x 556 x 180
- WK 0450 mA  
476 x 526 x 170

Manufactured by fabricator

**Worktop  
angular  
with tap ledge**

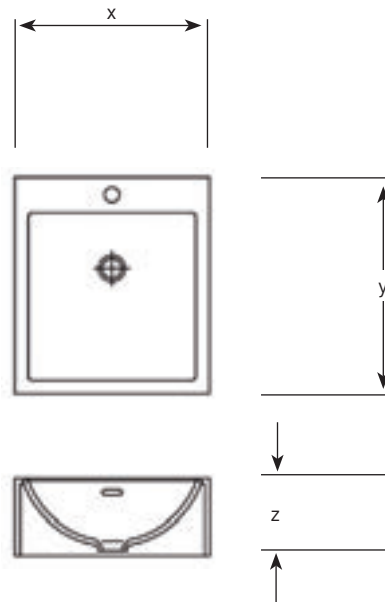

Available in the following dimensions:

- WE 0401 mA  
434 x 414 x 170
- WE 0501 mA  
534 x 436 x 170
- WE 0601 mA  
634 x 436 x 170
- WE 0801 mA  
828 x 436 x 170
- WE 1201 mA  
1220 x 486 x 170



**SAMSUNG SDI**

Manufactured by fabricator

**Worktop  
angular  
with tap ledge**

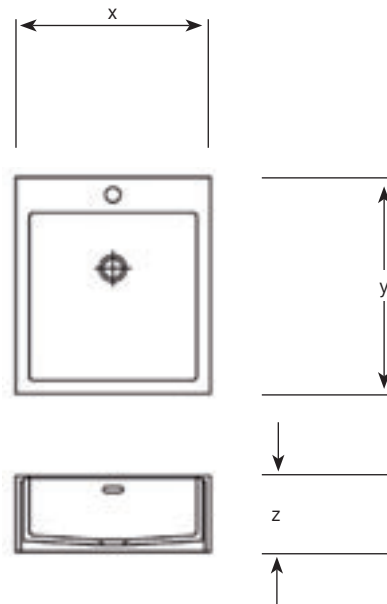

Available in the following dimensions:

- WE 0400 mA  
436 x 486 x 170
- WE 0462 mA  
498 x 548 x 170
- WE 0726 mA  
762 x 436 x 170
- WE 0745 mA  
781 x 461 x 170
- WE 1100 mA  
1136 x 436 x 170
- WE 4001 mA  
436 x 436 x 170
- WE 5001 mA  
536 x 436 x 170
- WE 5441 mA  
580 x 465 x 170
- WE 5751 mA  
611 x 561 x 170
- WE 6001 mA  
636 x 436 x 170
- WE 6041 mA  
640 x 436 x 170
- WE 6221 mA  
658 x 548 x 170
- WE 6751 mA  
711 x 511 x 170

# Product Overview

Manufactured by fabricator

## Shower trays

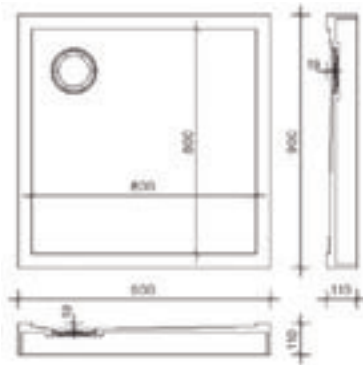

DT 0909 QA

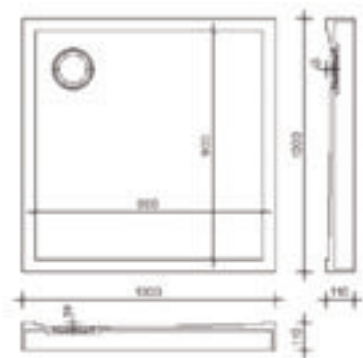

DT 1010 QA

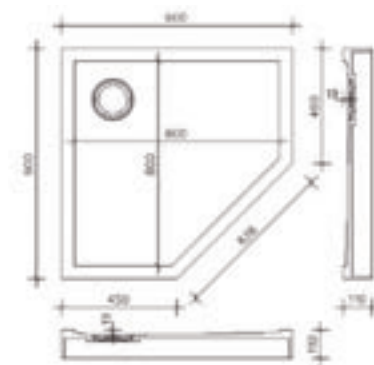

DT 0909 5E

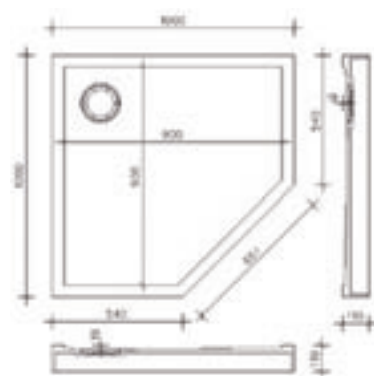

DT 1010 5E



SAMSUNG SDI



## **4 Planning and Design**

Basics  
Forming and radii  
Moulded parts technology

Inlays and backlighting  
Screw connections and heat protection  
Sublimation printing and surface finish





## Basics

### Aspects

The information shown is intended to act as basic information for project planning. It reflects current technological standards. We reserve the right to make revisions and additions in the light of future developments.

### Processing, general

STARON<sup>®</sup> is machined with carbide-tipped cutting tools in wood processing plants.

The essential processing steps are:

- sawing
- milling
- drilling
- bonding
- forming
- sanding



### Adhesion

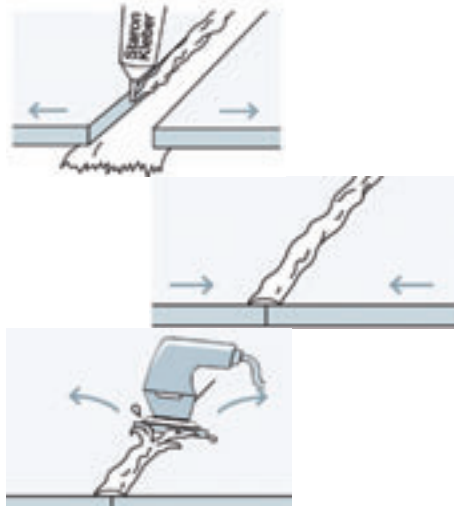

STARON<sup>®</sup> sheets are bonded together with a STARON<sup>®</sup> methyl methacrylate adhesive. The adhesive is coordinated with the sheet colour. After removing residual adhesive from the adhesion process and the final surface finish, the adhesive joints are nearly invisible.

### Expansion

The material-specific coefficient of expansion of  $30,5 \times 10^{-6}/K$  (corresponds to 1 mm per meter at a temperature difference  $\Delta T$  of 30°C) must be accounted for in all applications.

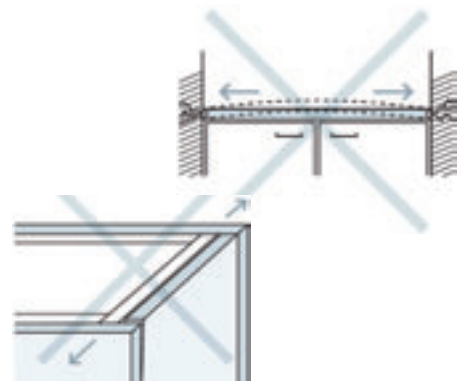

## Forming and radii

### Forming

STARON<sup>®</sup> sheets are thermoplastic and can be formed in three-dimensions. The possible forming radii depend on the material thickness and the material colour.

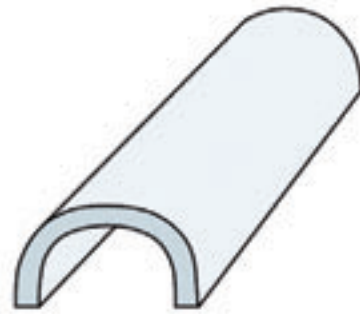

Sheet colour	Sheet thickness in mm	Radius in mm
Solid, Sanded	6	25
Aspen, Pebble	6	102
Solid, Sanded	12	76
Aspen, Pebble	12	127
Quarry, Metallic	12	203



Comments:

Deformations are generated either in a:

- a) vacuum process
- b) pressing process

The sheet material "Tempest" is only formable to a limited extent. We recommend thermoforming tests for special installations.

### Inner radii and grooves

Hygienically, the cleanest transition from the horizontal to the vertical STARON<sup>®</sup> installation is with a smooth radius which can be easily cleaned.. The radius is created from sheet elements, glued with STARON<sup>®</sup> adhesive and finally radially milled (R = 12.5 mm). The appropriate tools also allow for radii in internal corners.

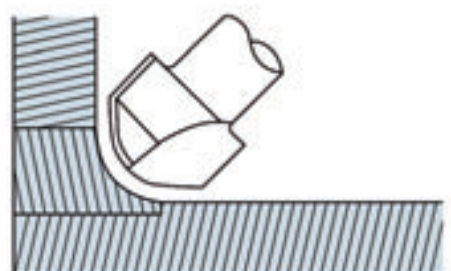
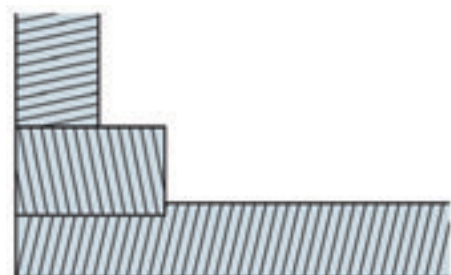

## Moulded parts technology

### Moulded part technology

The working and processing of STARON<sup>®</sup> allows for a creative and diverse development of moulded parts. Three basic processes are used to create the moulded parts.

### Casting process

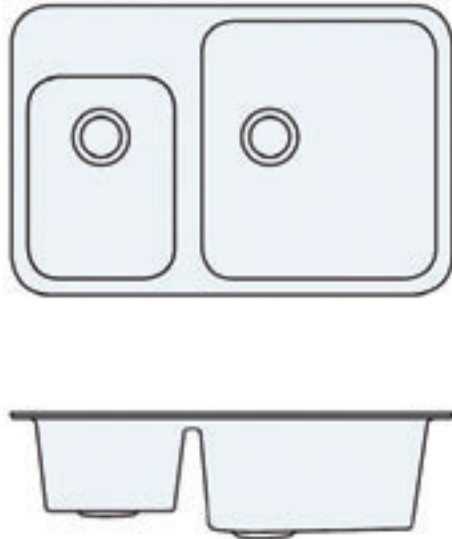

STARON<sup>®</sup> moulded parts with requirements applicable to the world market are cast in closed moulds by the Samsung manufacturing facility.

### Deep-drawing process

STARON<sup>®</sup> sheets are thermoplastic and can be formed in three-dimensions. Simple forms are manufactured under consideration (pressing or vacuum process).



### Combination process

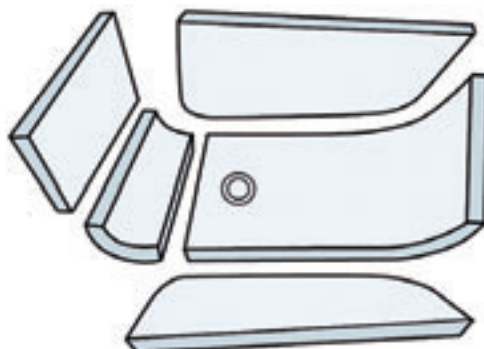

In the combination process, deep-drawn and bonding technologies are used together to create more complex moulded parts.



**SAMSUNG SDI**

## Inlays and backlighting

### Inlays

Using inlaying and adhesion techniques, STARON® offers two basic possibilities for designing inlays.

### Inserting inlays

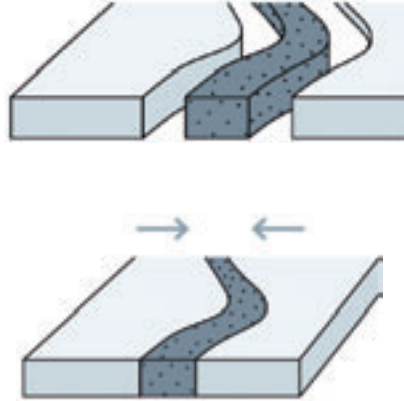

STARON® sheet elements are connected together with STARON® adhesive following prior milling (CNC). The colour structures of the sheets remain intact and complement each other.

### Casting inlays

Milled inlays (CNC routed) are filled in with colour-coordinated STARON® adhesive and ground until flush after hardening. The inlays are plain-coloured, homogeneous and can be colour-coordinated upon request of the customer.

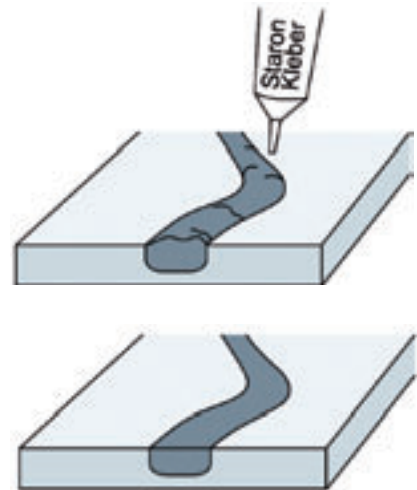

### Backlighting

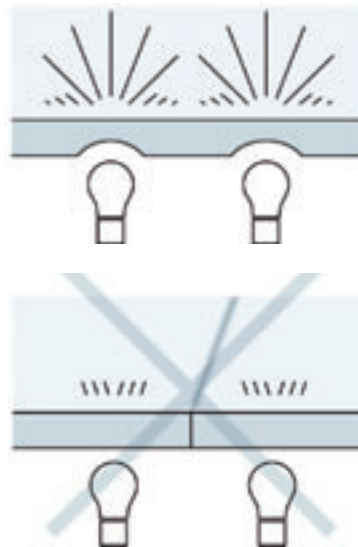

Special STARON® sheets (e.g. Dazzling White) are translucent and allow for the production of innovative light objects. Relief milling (material thinning) and colour inlays add to the design possibilities.

Sheet joints and adhesion joints in these areas generate shadows when backlit and should therefore be avoided or designed constructively. Note the manufacturing dimensions of STARON® sheets. Only use cold light sources.



## Screw connections and heat protection

### Screw connections

Never screw directly or with self-tapping screws.

Screw insertions must be executed with inserted plastic dowels.

Alternatives:

Penetrating screw connections or undercut/relief milling.

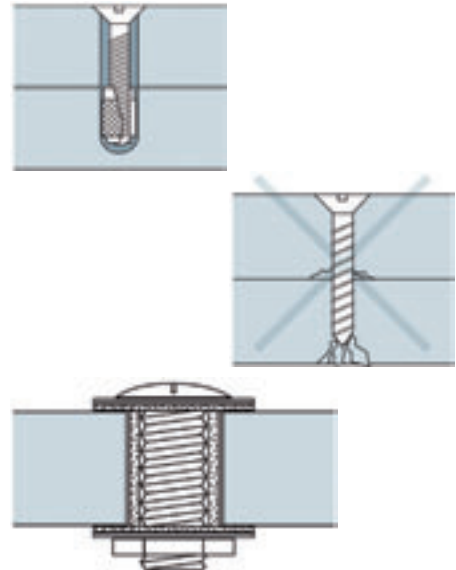

### Heat protection

When installing hobs and/or heat pads in STARON<sup>®</sup> sheets, please note:

1. Shaping of internal corners with decreasing radii
2. Reinforcement of internal corners and cut-out areas with STARON<sup>®</sup> sheet elements
3. Masking STARON<sup>®</sup> sheet edges with heat protection tape

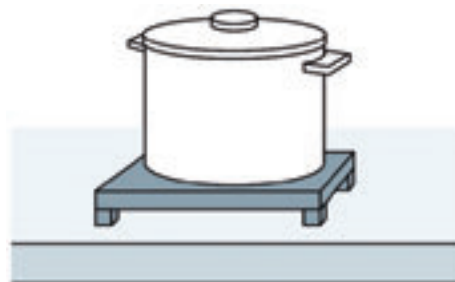
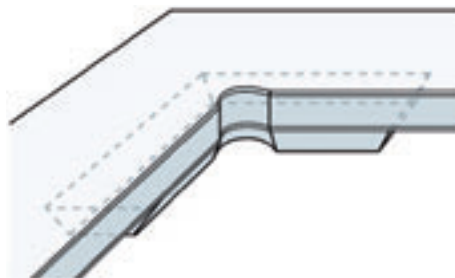

In comparison with other kitchen work-top materials, STARON<sup>®</sup> surfaces have excellent heat resistance. However, the surface may be damaged if hot pans or certain heat-generating devices, such as electric grills or fryers, are placed on it. To protect the surface, always use heat-proof table mats or trivets with rubber feet. Protect STARON<sup>®</sup> surfaces from extreme heat.

## Sublimation printing and surface finish

### Sublimation printing

In sublimation printing, images are transferred to the STARON<sup>®</sup> sheet material. STARON<sup>®</sup> sheets treated with sublimation printing can be further processed to a limited extent, exactly like untreated sheets. However, these processing operations rule out sanding. Sublimation printing offers many different possibilities for permanent and nearly UV-resistant design.

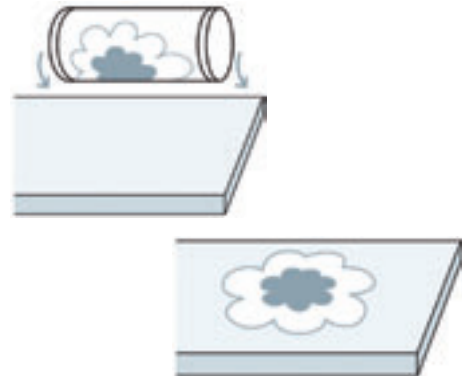

### Surface finish



Matte finish is the standard surface finish for heavy-used surfaces.



Satin finish is highly glossy and requires more care.



Gloss finish has a mirror-like shine and requires, depending on the use, more intensive care than matte and satin finish, especially for dark colours. It is recommended that gloss finish is used on vertical areas only.



The planning information shown above is intended as an excerpt from the processing guidelines, providing supporting information for detailed planning. Your STARON<sup>®</sup> fabricator would be happy to answer any further questions. Feel free to contact our **customer service**:

Samsung Chemical Europe GmbH  
Phone: +49 6196 66 74 34  
E-mail: [architect@samsung.com](mailto:architect@samsung.com)  
[www.staron-samsung.com](http://www.staron-samsung.com)





**5 Product  
Certifications**

Certifications  
Technological parameters





## Certifications

### Aspects

A wide variety of certifications are required depending on the country. The constant new areas of application of STARON<sup>®</sup> also entail new certificates. We constantly meet these requirements and update our documentation.



#### **Customer service:**

Samsung Chemical Europe GmbH

Phone: +49 6196 66 74 34

E-mail: [architect@samsung.com](mailto:architect@samsung.com)

[www.staron-samsung.com](http://www.staron-samsung.com)



**SAMSUNG SDI**

## Technological parameters

Tests	Standards	STARON® white	Requirement according to ISO 1972-1
Flexural resistance $\sigma_{fm}$		64.5 MPa	
Flexural modulus of elasticity $E_f$	EN ISO 178	9030 MPa	
Deflection		0.83%	
Compressive strength $\sigma_{dm}$	EN ISO 604	181 MPa	
Density	ISO 1183	1.74 g/cm <sup>3</sup>	
Surface hardness	EN 101	2-3	
Resistance to large balls	DIN EN 438-2	1,800 mm 12.2 mm material	1,300 mm
		700 mm 6.1 mm material	700 mm
Resistance to small balls	DIN EN 438-2	> 25 N 6.1 and 12.2 mm	
Resistance to abrasion	ISO 4586 p6	Weight loss determined	
Resistance to dry heat 180°C	ISO 19712/12.2	3	3
Resistance to steam	ISO 4586 p10	3	
Resistance to boiling water	ISO 4586 p7		
Weight loss		-0.16	
Change of thickness		0.013	
Surface change		5	
Light fastness	DIN EN 438-2	Grey scale > 4 Blue wool scale > 6	Blue wool standard = 5
El. deflection resistance	EN 61340-5-1	960x10 <sup>9</sup> Ω	
El. surface resistance	EN 61340-4-1	> 1x10 <sup>12</sup> Ω	
Fire protection	DIN 4102-01	B1	
<i>Anti-slip properties</i>			
Grain size 100µm	DIN 51130	R9	
Grain size 120µm	DIN 51130	R9	
Grain size 150µm	DIN 51130	R9	



**6 Care, Warranty  
and Service**

Usage and care  
Damage prevention  
Care of moulded parts and damage  
prevention

Warranty and service  
Disclaimer





## Usage and care

### **STARON<sup>®</sup> surfaces**

STARON<sup>®</sup> surfaces are resistant to everyday stresses and influences in both private and commercial usage. The semi-gloss surface created in production may change over time depending on the stress it is subjected to.

However, the original appearance can be maintained if the care and usage information is observed. The surface can even be restored the appropriate means at any time. This guarantees an attractive and functional STARON<sup>®</sup> installation for many years.

### **Daily care**

A thorough cleaning of STARON<sup>®</sup> surfaces can be performed by wiping them off with a damp cloth or sponge and, especially in regions with hard water, by subsequently drying them off with a soft cloth or tissue.



### **Normal stains**

The surfaces are cleaned with an ammonia-containing product, such as household glass cleaner, or with commercially available, non-abrasive spray cleaners for mineral material

products. Wipe the surfaces dry with a soft cloth or tissue to prevent streaking.

### **Stubborn stains**

STARON<sup>®</sup> sheets are available in over 140 colours and every colour can be delivered by a certified STARON<sup>®</sup> fabricator/installer with different surface finishes. STARON<sup>®</sup> surfaces with dark colours and a glossy surface finish may exhibit signs of use, such as scratches and soap residue, more clearly than lighter surface materials. The gloss finish therefore requires additional maintenance and care to preserve its original shine. Depending on the finish type and colour, different cleaning

techniques are required to remove stubborn stains and smaller scratches as described in the following instructions (Note: Please consult your certified STARON<sup>®</sup> fabricator/installer if you are not sure which type of surface finish your STARON<sup>®</sup> mineral material surfaces have). Do not attempt to repair deeper scratches or splintered or burned points; please consult a certified STARON<sup>®</sup> fabricator/installer.

## Usage and care

### Surface-specific care

#### Matte finish

is the standard surface finish delivered by certified STARON<sup>®</sup> fabricators/installers. It has no or minimal gloss and is recommended for all areas subjected to heavy use.

Polish the surfaces with a circular motion using a damp sponge and a cleaning powder such as Soft Scrub<sup>®</sup>. Darker colours generally require more care than lighter colours

#### Satin finish

has a stronger gloss than matte finish and requires more care depending on frequency of use and application area.

Lightly polish the surfaces with stains or scratches with a circular motion using a damp sponge and a cleaning powder such as Soft Scrub<sup>®</sup>. Darker colours generally require more care than lighter colours. Polishing too aggressively can even reduce the gloss

#### Gloss finish

shines more strongly and reflectively and requires more intensive care. It is important to note that gloss finish, especially on a dark colour, requires more care than matte or satin finish. You should therefore make sure when caring for gloss surfaces that you do not apply the methods or procedures recommended for matte or satin finish. Repeat the procedure as described below. If the stain cannot be removed, please ask your certified STARON<sup>®</sup> fabricator/installer for assistance.



Do not use scouring agents and abrasive sponges for surfaces with gloss finish; please consult your STARON<sup>®</sup> dealer for more information.

Spray a non-abrasive product such as Formula 409<sup>®</sup> on the stain and allow several minutes for it to take effect. Then polish the surface with a damp sponge with a circular motion. Darker colours generally require more care than brighter colours. Polishing too aggressively can even reduce the gloss. Do not use scouring agents, abrasive sponges or steel wool. After proceeding as described above, rinse with clear water and rub the surface dry with a soft cloth or tissue in order to prevent streaking. In order to improve colour clarity and to hide small scratches, apply Magic<sup>®</sup> cleaner for kitchen worktops (available in all hardware stores and supermarkets) and wipe off the excess with a soft cloth.





## Damage prevention

### Damage prevention

A certified STARON<sup>®</sup> fabricator/installer or repair specialist can usually repair minor damage. However, in order to prevent damage to your STARON<sup>®</sup> surfaces, you should observe the following recommendations.

### Heat

In comparison with other kitchen worktop materials, STARON<sup>®</sup> surfaces have excellent heat resistance. However, the surface may be damaged if hot pans or certain heat-generating devices, such as electric grills or

fryers, are placed on it. To protect the surface, always use heat-proof table mats or trivets with rubber feet. Protect STARON<sup>®</sup> surfaces from extreme heat.

### Chemicals

Do not expose STARON<sup>®</sup> surfaces to such aggressive chemicals as paint removers, acetone or oven cleaners. Surfaces exposed to such chemicals should be immediately rinsed with

water; contact may lead to stains requiring extensive repair work.

Remove nail varnish with acetone-free nail varnish remover and rinse with water.

### Scratches

Never cut directly on a STARON<sup>®</sup> surface. Always use a cutting board.

### Cracks

Do not stand on STARON<sup>®</sup> surfaces and never allow heavy objects to fall on the surfaces.

### Note

Loss of gloss, scratches and stain formation on STARON<sup>®</sup> surfaces accumulated over time are **not** manufacturing faults, but rather fall within normal wear and are therefore **not** covered by the limited STARON<sup>®</sup> warranty. If the STARON<sup>®</sup> product is deeply scratched, please consult your dealer or certified STARON<sup>®</sup> fabricator/installer for information on the most effective method of repair – most repairs can be executed relatively simply and easily by an expert (customer service charges may apply).

For more detailed information, please consult your STARON<sup>®</sup> dealer or go to our website **[www.staron-samsung.com](http://www.staron-samsung.com)**. The use of certain names are intended only to illustrate cleaning product types and do not represent recommendations or advertisements for the respective products; conversely, the non-mention of a certain product does not mean that it is not suitable for use.



## Care of moulded parts and damage prevention

<b>STARON<sup>®</sup> moulded parts</b>	STARON <sup>®</sup> moulded parts (sinks and basins) are highly resistant to normal stains caused by food products, liquids and cosmetics.	However, if food remains and chemicals are left for an excessive period on the surface, causing them to dry on, a stubborn stain may result.
<b>Daily care</b>	Wash off regularly with Soft Scrub <sup>®</sup> or a mild cleaner, such as dishwashing detergent.	
<b>Stubborn stains</b>	Apply a mild scouring agent such as Bon-ami <sup>®</sup> , Comet <sup>®</sup> or Soft Scrub <sup>®</sup> to the surface and polish it with a circular motion using a white Scotch-Brite <sup>®</sup> abrasive sponge.	Polish the entire sink to homogenise the surface and then rinse off the surface again – the colour of the STARON <sup>®</sup> product remains visible the entire time.
<b>Disinfection</b>	To keep kitchen sinks clean, occasionally apply liquid bleaching agent and water as follows: <ul style="list-style-type: none"><li>• Fill the sink ¼ with water and add 1–2 portions of bleaching agent.</li></ul>	<ul style="list-style-type: none"><li>• Carefully scrub the entire surface (without spraying) with a green Scotch-Brite<sup>®</sup> abrasive sponge and a cleaning sponge.</li><li>• Leave the water in the sink for 15 minutes, then drain the water and thoroughly rinse the sink.</li></ul>
<b>Damage prevention</b>	STARON <sup>®</sup> moulded parts (sinks and basins) are highly resilient. However, please observe the following: <ul style="list-style-type: none"><li>• Allow heated dishes to cool off before placing them in the sink</li><li>• Always run cold water when you allow boiling water or hot liquids to run into the sink</li><li>• Do not expose the surface to aggressive chemicals such as paint remover, turpentine, nail varnish remover or drain-pipe, stove or toilet cleaners. If such chemicals come into contact with the surface,</li></ul>	immediately wash it off with water, observing the applicable safety measures for preventing injury <ul style="list-style-type: none"><li>• Do not allow heavy objects to fall on the surface</li></ul> <p>The use of certain names are intended only to illustrate cleaning product types and do not represent recommendations or support for the respective products; conversely, the non-mention of a certain product does not mean that it is not suitable for use. For more detailed information, please consult your STARON<sup>®</sup> dealer, STARON<sup>®</sup> fabricator or visit our homepage.</p>



## Warranty and service

### Limited 10-year warranty for STARON<sup>®</sup>

Samsung SDI provides owners of STARON<sup>®</sup> installations for private living areas manufactured in accordance with Samsung processing and application guidelines with a limited 10-year warranty.

Samsung SDI assumes no liability for damage resulting from defective material (STARON<sup>®</sup> sheets, STARON<sup>®</sup> moulded parts, STARON<sup>®</sup> adhesive). Samsung SDI is obligated to restore the original condition of the product by means of repair or replacement should a warranty claim be justified.

Additional adhesion joints or minor colour differences entailed by the repair must be tolerated. If, in case of a warranty claim, it is not possible for Samsung SDI to remedy damage within an appropriate period following acknowledgement of the damage by means of repair or replacement, the customer shall be reimbursed the acquisition price according to the table below. Warranty claims are to be managed exclusively by bodies authorised by Samsung SDI. Costs generated by a warranty claim are calculated on the basis of the table below. Follow-up costs generated by the warranty claim, e.g. loss of use, for dismantling furniture or for renovation work, are not covered by the warranty.

### Warranty period

Warranties are based on the following periods:

- in the 1st to 3rd year from the installation date:  
100% of the material and labour costs\*
- in the 4th to 6th year from the installation date:  
75% of the material and 50% of the labour costs\*
- in the 7th to 9th year from the installation date:  
50% of the material and 25% of the labour costs\*
- in the 10th year from the installation date:  
25% of the material and 0% of the labour costs\*
- The labour costs cover: travel costs, wages and necessary costs for consumables.

### Warranty exclusion

The following are **not** covered by this warranty:

1. Damaged caused by improper use.
2. Damaged caused by improper and insufficient care.
3. Damage resulting from improper assembly.
4. Damage caused by faulty fabrication and non-observance of the processing guidelines.
5. Damage caused by rearrangement of or modifications to the original installation.
6. Damage caused by chemical or physical misuse.
7. Damaged caused by heat.
8. Changes of appearance caused by improper use, e.g. gloss changes or signs of use.
9. Follow-up damage caused by the improper use of STARON<sup>®</sup>.
10. Damage caused by natural or environmental disasters or through vandalism or war-related influences.



**SAMSUNG SDI**

## Warranty and service

### Warranty exclusion

The warranty begins at the installation date entered in this warranty card and is valid for a period of 10 years. This warranty can be carried over within this 10-year period only if the new owner registers himself/herself as the owner, specifying

the warranty number and the date of the first installation. If a legal amendment renders one or more points ineffective during the warranty period, the other points still remain valid. This warranty is based on the law of the Republic of Korea and is effective from 1/1/2002.

### Disclaimer

The contents of this manual were prepared by the manufacturer with the utmost care. These contents are updated regularly and promptly. However, errors in the manual cannot be ruled out entirely. We welcome you to send any information, corrections as well as suggestions for improvement to the contact address indicated in the manual.

Despite careful examination, we cannot assume full liability for the accuracy, completeness and up-to-date-ness of this manual. In particular, the manufacturer assumes no liability for any damage or consequences arising from the use of the contents offered.

### Service

Our extensive know-how is based on the experience we have gained in manufacturing, planning and processing STARON<sup>®</sup> over many decades. Samsung gives customers and

planners access to this know-how in the scope of cooperative service programmes for current projects and future product developments.

### Contact data



#### Customer service:

Samsung Chemical Europe GmbH

Phone: +49 6196 66 74 34

E-mail: [architect@samsung.com](mailto:architect@samsung.com)

[www.staron-samsung.com](http://www.staron-samsung.com)



**SAMSUNG SDI**











## 9 Reports





## 10 Ideas and Notes









**SAMSUNG SDI**

**SAMSUNG CHEMICAL EUROPE GMBH**

Am Kronberger Hang 6  
65824 Schwalbach/Ts., Germany  
Tel.: +49 6196 66 74 34  
Fax: +49 6196 66 74 66/67  
E-mail: [architect@samsung.com](mailto:architect@samsung.com)  
[www.staron-samsung.com](http://www.staron-samsung.com)